

Lindenwood University

Digital Commons@Lindenwood University

---

Theses

Theses & Dissertations

---

8-1982

## The Value of Antiquities: Historical Development and Evaluation of Trends in the Current Market Through Graphic Analysis and Sales Data Compilation

Mary Thornton Holton

Follow this and additional works at: <https://digitalcommons.lindenwood.edu/theses>



Part of the Business Commons

---

Lindenwood Colleges

**THE VALUE OF ANTIQUITIES:**

**Historical Development and Evaluation of Trends in the  
Current Market through Graphic Analysis and  
Sales Data Compilation.**

Culminating project submitted in candidacy for the  
Degree of Master of Arts  
Department of Valuation Sciences

by

**Mary Thornton Holmes**

St. Louis, Missouri  
August, 1982

© M.T. Holmes 1982

## ACKNOWLEDGMENTS

The author gratefully acknowledges the technical advice and assistance of Jim Oetting, Systems Analyst, IBM, and Brooke Petersen and Thom Husted, Word Processing Specialists.

## TABLE OF CONTENTS

ACKNOWLEDGMENTS .....	ii
INTRODUCTION .....	1
Chapter	
I. HISTORY AND REVIEW OF LITERATURE ON VALUATION OF ANTIQUITIES .....	3
II. DEVELOPMENT OF THE VALUE OF ANTIQUITIES, HISTORICALLY, SOCIALLY, AND ECONOMICALLY .....	4
III. CULTURAL PROPERTY LAWS .....	16
IV. GRAPHIC PORTRAYAL OF TRENDS IN THE ANTIQUITIES MARKET .....	27
V. METHODOLOGY FOR VALUATION OF FINE ARTS .....	35
INFORMATION CATEGORIES:	
Compilation and Processing of Sales Results	
School or Artist	
Geographic Location	
Period	
Medium	
Subject Matter	
Dimensions	
Condition	
Provenance	
Quality	
Rating System	
VI. CONCLUSION .....	41
APPENDIX I .....	43
APPENDIX II .....	68
APPENDIX III .....	91
BIBLIOGRAPHY .....	107

## INTRODUCTION

The purpose of this project will be to examine some of the most central issues in the evaluation and methodology for valuing the category of fine arts known as antiquities. This category covers several historical periods and includes artifacts which originate anywhere in the present countries of Egypt, Greece, or Italy from 4000 BC in the pre-dynastic ages of Egypt through the various dynasties of the Pharaohs, through the Minoan, Mycenaean, Archaic, Classical, and Hellenistic ages of Greece, and through the times when the Roman Empire rose and dominated practically the entire known world. The final date which defines antiquities is 336 AD, when the pagan world officially converted to Christianity under the Emperor Constantine.

The initial chapter will focus on the history and review of the literature on valuation of antiquities.

The second chapter addresses the examination of the development of the value of antiquities historically, socially and economically from the beginning of their manufacture in 4000 BC through all the various ages of the ancient world and through every major century up to the present time. This section will look at some of the issues that have influenced their value, their popularity, and their falling out of favor.

The third chapter will review some of the legal and social implications and incidents which have occurred since they were made, and we will try to give a broad background of the historical value up to the present time of antiquities. With this background, the paper will go on in the fourth chapters to analyze the antiquities market, using the methodology of gathering data and computation of prices to form a

graphic portrayal of trends in the art market and to provide information for a data recall system. From this, a methodology has been developed and will be presented which can be applied to other categories of fine art as well.

The section of this culminating project which deals with the utilization of word processors and technology will be, to the knowledge of the writer, breaking new ground in this field. The large auction houses of Sotheby Parke Bernet and Christie's utilize a computer inventory and recall system. This system, however, for reasons of confidentiality, is not available to the general public. After lengthy discussions and conversations with appraisers across the country and around the world, it is evident that there is a crying need for a methodology which can be utilized by appraisers. This methodology using a computer would enable the appraiser to have at his or her fingertips instant recall of comparables from many fields. It is the hope of this writer that after this first attempt at such an analysis and methodology, a major breakthrough will occur for the appraising profession of personal property by utilizing data technology, a system by which appraisers can record all the necessary market comparable information onto a data recall program will be introduced. Through an analysis of the historical, social and economic aspects which have influenced the value of antiquities, combined with a utilization of modern technology, appraisers can gain a deeper understanding of the objects and their place in past, present and future markets.

## CHAPTER I.

### HISTORY AND REVIEW OF THE LITERATURE

Much literature in regard to the art historical and cultural aspects of ancient objects is available in any language you can possibly imagine throughout the Western world. Scholars have spent lifetimes analyzing the significance of the artifacts, the historical context, and the deciphering and interpretation of unknown languages and hieroglyphics. The literature in this aspect of the field is vast, rich, and ever-growing.

The literature dealing with the market and monetary values of antiquities, however, is very slim. In fact, except for some of the large auction houses, which publish catalogues and their price lists, and a few scant compilations of the art at auction, there are very few references in any sources to the monetary value of antiquities. The two sources which had some treatment of sales results in Antiquities were Art at Auction by Dr. Hans Weinhacher and The Economics of Taste by Gerat Reitlinger. There was no reference in the ASA bibliography to the market on antiquities. There are several reasons for this situation, most of which will be discussed and analyzed later in this culminating project. The most outstanding feature of antiquities is that they are a very exclusive, rather obscure category of art which does not have the glamour and publicity connected with it like some of the other larger categories, such as painting or sculpture.

## CHAPTER II.

### DEVELOPMENT OF THE VALUE OF ANTIQUITIES, HISTORICALLY, SOCIALLY, AND ECONOMICALLY

Egyptian art originated in 4000 BC and continued through 332 BC when Alexandria was founded by Alexander the Great and Egyptian art in the Egyptian world was basically Hellenized. There is surprisingly little change in Egyptian art throughout this vast span of time, and the main characteristic of the Egyptian art is that it is essentially static, which reflects the Egyptian view of reality. In origin, nearly all Egyptian art forms were created to sustain the divinity of the Pharaoh, the god incarnate, who was regarded as creating the universe anew in the old pattern at its advent. He alone was the chief instigator and patron of artistic enterprise in dynastic times. Since the traditions of kingship were sacrosanct, by the time a world iconography had reached a fully expanded form at the end the fourth dynasty, no compulsion was ever felt to depart from its conventions. Gradually, from being an absolute overlord, the Pharaoh came to share political power with feudal rivals, powerful enough to usurp his functions by the time of the first intermediate period. New classes of men, artisans and minor officials appear as modest patrons at this particular period, but do not at first impose any distinctive taste, their needs being met by the cheaper copies of aristocratic art forms. While officially a god, the Pharaoh, despite all traditional pronouncements, appears now as the heroic warlord boasting of a superhuman prowess in the hunt on the battlefield. Despite these changes in art patronage, Egyptian art changes relatively little during this entire time. Certain characteristics developed, but the main style remains the same. The patrons throughout this entire period are members of the upper class and the artists themselves are merely slaves commissioned to do the work for the upper classes: the kings, the pharaohs, and members of the nobility. The cost was minor since slaves



executed most of the work and, obviously, did not get paid. And the purpose of the art was always the same: to immortalize the nobility and to present a world that was to come after life and which would be more pleasant than the life here on earth.

There is a mixing of Greek and Egyptian elements after Alexander the Great established Alexandria as a cultural center. Gradually the patrons of Egyptian art became totally Hellenic and eventually Roman. Most of Egypt became a provincial backwater, with the exception of Alexandria. Egyptian motifs were passed on in a modified form to Greek art and then became stylish with the nobility of the Roman Empire. Egyptian art continued to be produced but there was a small demand for it and the religious subjects by various smaller kings who remained in the Egyptian territory until Justinian finally closed down any sort of pagan practice in Egypt in 543 AD.<sup>1</sup>

Greek civilization originated in 3000 BC and had different phases of the Minoan, Mycenaen, Classical and Hellenistic Ages. Most of these periods were ages of an oligarchy, or rule of the few, and these people were also the patrons of the art. Greek civilization rose to its height of power and culture in what are known as the Classical and Hellenistic Ages, which occurred in the 4th and 5th centuries BC. These were the ages of cultural, artistic and political development under the guidance of men such as the great playwrights Sophocles, Euripides and Aeschylus; the great sculptors Praxiteles and Phidias; the brilliant politician Pericles; and later, the overwhelming conqueror, Alexander the Great who, by the age of 33 had "Hellenized" the entire

---

<sup>1</sup>Smith, N. Stevenson, The Art and Architecture of Egypt, Baltimore, Penguin Books, 1958.

known ancient world as far as India. These amazing developments and ideas have influenced the Western World ever since. The artistic objects which are the physical remains of this culture have had a fascination to collectors over the centuries because they symbolize the classical ideal of intellectual, as well as bodily harmony and proportion.

Greek metal and marble sculpture was usually created for temples or public monuments by anonymous craftsmen who were directed by an overseeing sculptor/architect such as Phideas. The art usually depicted scenes from ancient mythology showing the adventures and escapades of the Olympian gods and how they influenced man. They also made statues of idealized human figures which showed the balance between physical and mental excellence. Finally, in the 5th century BC, the sculptor began to show signs of depicting current events such as the Pan-Hellenic procession which occurred every four years in Athens, and eventually portraiture appeared in Hellenistic times when individualism took precedence over any thoughts of a communal good.

In addition to sculpture, the lesser art of ceramics was also prolific at this time and was a product of large workshops which sometimes even produced a craftsman so gifted that he would sign his name to a piece because this made it more desirable. The pottery was used either for votive offerings or religious rituals, or were simply used before the daily functions of drinking, pouring, storing and transporting.

The concept of collecting in the Classical Age of Greece was non-existent. The aristocracy gave money for the large statues and monuments because it was their duty to support the artistic development of the community. Not only were they obligated

to support the fine arts, but also the performing arts as well, not to mention providing the financing for defense and armaments. The lesser art of ceramics, of course, had a more immediate function, therefore, pottery was not only made in larger quantities, but was also patronized by a more diverse public. But even the quality of craftsmanship and design in these objects shows the extremely high standards that were expected in this art as well. After the Golden Age of Athens, the art became more personal. The patron began to ask for subjects which were more suitable to decoration of private homes, rather than public monuments. The increased contact with other peoples and cultures caused an appreciation and awareness to develop about diverse art forms, and people began to collect from all over the world. But it was not the Greeks themselves who were the most avid admirers of their own past. It was the Roman enthusiasm for all things Hellenic that caused a renewed interest in Classical and Hellenistic art. Roman civilization had been in existence since 400 BC and spread its influence and culture all over the ancient world until 336 AD, at that point the Emperor Constantine not only declared Christianity to be the official religion of the Roman Empire, but he also changed the Empire center of operation from Rome to Byzantium, or what was to be later called Constantinople. The Romans did not collect their own creations, nor a great deal of Egyptian art. Statues for public display were copied from Greek examples and sometimes the Roman version was so flawless that it was hard to distinguish from the Greek original. But private collectors emerged to obtain the originals. They tried to possess everything by purchase or pillage. There were auctions in Rome which sold Greek antiquities and a new class of connoisseurs arose who were experts at spotting an original. Naturally, another class of forgers

also appeared, who were equally expert at creating "original" works by Greek masters.<sup>2</sup>

The Romans admired Classical art because it embodied an intellectual tradition which they felt was lacking in their culture. Pieces of art from the Golden Age of Greece filled private homes which were open to the public on certain days. Finally, Agrippa, in the 1st century, declared a plan to nationalize the most important objects to prevent their being exported to distant colonies.<sup>3</sup> This did not prevent the collecting from continuing, however Greek art enjoyed a high position throughout the period of the Roman Empire until the beginning of the Christian era.

Probably the reason why Egyptian art did not enjoy such popularity as the Greek art did during the Roman Empire, was that it symbolized a culture and a philosophy which was basically foreign to the Roman way of life. Egyptian art dealt mainly with the dead and life after death and had nothing to do with celebrating the life of the here and now. Even the gods, pharaohs and kings which it depicted were idealized forms of how these personages would act in a life after the present life. The Romans perhaps felt a little uncomfortable with this philosophy since they were a much more temporal and pragmatic people.

In the reign of the Emperor Constantine, the interest in Greek and the lesser interest in Egyptian antiquities was considered in poor taste and fell out of favor for many generations, even centuries. Sometimes the Greek and Egyptian statues and

---

<sup>2</sup>Bonnaffi, Edmond, Les Collectionneurs de l'Ancienne Rome, A. Dubry, 1967.

<sup>3</sup>Rheims, Maurice, The Strange Life of Objects, Atheneum Publications, New York, 1961

sculpture were destroyed because they represented images of something other than the true Christian God. The patrons, the church and the state officials (most often inseparable), preferred Byzantine icons with their subjects taken from the Old and New Testaments to the "corrupt" ancient art. One can see, however, a strong influence of the Egyptian stylized forms of art in the Byzantine iconography. In western Europe, the attitude was much the same during the entire Middle Ages. Although the New Testament was written in Greek, and all Christian scholars were fluent in Greek and Latin, and in spite of the fact that Greek was the official language of the Byzantine Empire, the sympathy for ancient tradition went no further. The attitude toward Egyptian traditions was much the same in that the Egyptians worshipped gods and pharaohs, many of them different, of course, from the Christian God, and the Egyptian concept of the after-life which was basically a better life than the one here now on earth had similarities with the Christian concept. But the Egyptian after-life was exclusive only to and subservient to the pharaohs and kings that were immortalized and were not based on any sort of philosophy of salvation due to Christ coming on this earth or to any sort of reward for good Christian behavior. The Middle Age's aversion to the Egyptian, Greek and early Roman cultures was a natural attitude for a civilization which believed that the world has been saved with the coming of Christ.

The unpopularity of antiquities continued until the Italian Renaissance when the humanists showed a reawakened interest in the past which they felt had a "purer" tradition. The artists and intellects of the 16th century practically worshipped the Greek and Roman artifacts and antiquities and many of the wealthy families began to collect avidly any works they could obtain. The Medici palace, for example, had a

huge sculpture garden dedicated only to ancient statues. The artists of the time consciously tried to discover the secrets of the ancient technique of proportion.

The Renaissance was a time of struggle between innovators and the traditionalists. There was an uncertainty about the future because of unsettling scientific discoveries, devastating wars, and strife within the Church which eventually led to the Reformation. Since there was an unstable atmosphere, it was natural that men would admire and romanticize about the images of a more seemingly coherent and less threatening time. The educated humanists made a conscious effort to return to this past era. Finally, the fiction that the Renaissance could go back to "Golden Age" proved illusory and an age of doubt ensued which lasted into the 18th century.<sup>4</sup> This age of doubt was replaced by an era of revolution when the bourgeoisie triumphed over aristocratic authority. The 18th century is a period of naturalism and rationalism which supplanted the more exclusive tastes of the extravagant upper classes. There is a romantic trend to revert back to the purity and simplicity of ancient times which is simultaneous with the appearance of scientific archeological excavations which began with Winkelmann and which were given wide publicity during the discoveries of Pompeii in 1748 and Herculaneum in 1737. There was a stream of pilgrimages to the Mediterranean countries, notably Egypt, Greece and Italy. A journey to these countries was considered an essential part of a young person's training. Contemporary artists, most notably David, deliberately copied the Classical and Egyptian styles of dress, coiffures, and architecture, and this imitation lasted well into the 19th century.<sup>5</sup>

---

<sup>4</sup>Hauser, Arnold, Mannerism, Alfred A. Knopf, New York, 1965, p. 10-ff.

<sup>5</sup>Hauser, Arnold, The Social History of Art, Alfred A. Knopf, New York, p. 131ff, Volume 3.

Collecting of Greek, Roman and Egyptian art was also revived in the 18th century. It became a passion and considerable sums were spent on antiquities. Not only was this a past time for connoisseurs and experts, but also it became accessible to middle class patrons, who used their newly acquired collections as a means of displaying their cultural knowledge and power. Art became more and more democratized and a desire to make art available to a wide public (once again as a means of display) led to the foundation of national museums, such as the British Museum, the Vatican, the Hermitage, the Louvre, and the Glyptothek Museum in Munich. Eventually a sentiment grew up that it was the privilege and duty of a citizen to glorify his nation by adding to its national collection.<sup>6</sup>

Not only did gentlemen believe that it was their duty to collect, but also the leaders of conquering armies, most blatantly Napoleon, believed it was their right to carry off ancient artifacts as part of their spoils. After his final defeat, many of the ancient sculptures Napoleon had confiscated were to be repatriated. It became necessary for the experts to set a monetary value on the works which were retained in the Louvre in order to settle the question of fair compensation. In this way, Egyptian, Greek, and Roman statues acquired a universal standard of market value.

The founding of the British School of Archeology in Athens in the late 18th century increased interest in antiquities considerably. Now the professional archeologist used his skill and knowledge to excavate works of art which were immediately shipped back to England and added to the British collection. Private "archeologists" also took advantage of the situation by acquiring their own impressive

---

<sup>6</sup>Grant, Judith, The Pillage of Art, Robert Hale, 1966.

collections from Egypt, Greece and Italy. The most famous of these men is Lord Elgin, who was the British Ambassador to Constantinople at the beginning of the 19th century. By seducing the Turkish officials, who had power over the Greek territories at this time, he was allowed to ship back to England a large portion of the marble sculptures which decorated the Parthenon on the Athenian Acropolis. In 1816, because of financial difficulties, he sold this collection to the British government for the sum of 35,000 £ (at the time the equivalent to \$16,000 U.S.).

In 1832, when Greece was recognized as an independent kingdom, the new government forbade the export of any "works of artistic or archeological value" from Greece.<sup>7</sup> But Hellenic antiquities were still available from the Turkish authorities in Asia Minor until the end of the 19th century when the Turkish government made a similar ruling. This eventually forced collectors to be satisfied with treasures obtained at high priced art galleries, or from equally high priced smugglers. The laws in Italy and Egypt were much slower to be instigated, but eventually they had similar legal rulings similar to the one in Greece. During this entire time, however, smuggling was a very active and profitable profession and, despite official efforts, was never suppressed.

Removal of artifacts from Greece, Egypt and Italy declined somewhat, but archeologists continued to excavate. Schliemann and Blegen were two German archeologists who contributed to giving world recognition and support to the profession at the beginning of the 20th century with their excavations at Troy in Asia Minor, Mycene in the Pelopponese of Greece, and the Minoan ruins of Knossos on Crete. A certain romantic mysticism about the actual digs gave ancient artifacts added value.

---

<sup>7</sup>Ibid., p. 200.



This was mainly brought to the fore during the excavations by Lord Carnarvan, a Scottish lord who, with the assistance of Howard Carter, excavated the tomb of King Tut in 1922 in the Valley of the Kings in Egypt. Several strange and mysterious occurrences which happened at this time gave rise to a somewhat exaggerated myth that there was a curse on this tomb.<sup>8</sup> This publicity whetted the appetite of many and private collectors and museums became extremely active in the collecting of Egyptian as well as Roman and Greek artifacts.<sup>9</sup>

During this entire span of time, there is a frustrating lack of actual recorded prices or sources of the sales of antiquities. In the 1920s, however, this situation changed when the prices began to be permanently recorded. At this time, collectors were willing to pay \$12,000-\$18,000 U.S. for Greek painted pottery.<sup>10</sup> These prices declined somewhat in the early 30s only to rise again in 1936 when the Olympic games in Berlin and the subsequent excavations at the original site of the games in Olympia in Greece once again brought antiquities into the limelight.<sup>11</sup> In the 1940s, during World War II, activity in the antiquities market picked up somewhat because many of the treasures which were housed in the great museums of Europe were hidden to avoid damage. A number of these pieces were never recovered or mysteriously

---

<sup>8</sup>Vainowski, Bob, King Tut's Tomb and the Curse, C.S. Production, 1979.

<sup>9</sup>Schreiber, Lady Charlotte Elizabeth Guest, Lady Charlotte Schreiber's Journals, London, John Land, 1911 / Spitzer, Frederic, La Collection Spitzer, Macon Pretat Freres, 1904 / Caubet, Annie, Curator of Antiquities, The Louvre Catalogue of Antiquities, Paris, Editions L'Indispensable, 1978/John Phillips, editor, The British Museum Catalogue of Greek and Roman Antiquities, London, Phaidon Press, 1973.

<sup>10</sup>Sotheby Parke-Bernet, Art at Auction 1920-1921, New York, Viking Press, 1921.

<sup>11</sup>Lehmann-Haupt, Hellmut, Art Under a Dictatorship, New York, Oxford University Press, 1954.

"disappeared," only to be sold through the underground art market. In addition to this, the desirability of these pieces was enhanced because of the new importance attached to freedom and democracy. The classical artifacts once again became the embodiment of a golden age of enlightenment. Before World War II, not only did the excavations in Egypt enhance the desirability of Egyptian artifacts and styles, but the artifacts and the discoveries initiated a new movement in art called Art Deco, which simulated many of the stark lines and stiff formality of the Egyptian style.

The romanticizing sentiment toward Greek and classical art has disappeared since the end of World War II. In the 1950s and 1960s, ancient artifacts had been viewed as a period type of art which is collectible for certain specialized connoisseurs and museums. Practically all Egyptian antiquities, which became surprisingly numerous in the 50s and 60s, did not bring very much money and did not command any sort of high popularity. Greek pottery and terra cotta did not fare much better. Roman glass, however, maintained its value. This is because the ancient glass blowers were never able to achieve the symmetry and formalism of classical pottery and metal qualities which were repugnant to the taste of the times. They produced a subtle asymmetry which, combined with the effects of iridescence, resulted in pleasing the modern taste.<sup>12</sup>

The antiquities markets continued to be slow but active through the 1960's and into the 1970's. But prices paid at auction have been very low in comparison with the skyrocketing amounts which were paid for paintings and other forms of fine arts. The

---

<sup>12</sup>Reitlinger, Gerat, The Economics of Taste, Berry & Rockleff, London, 1973, Volume III, p. 471.

records of the early 1970's show little change.<sup>13</sup> This would tend to show that the collectors and museums which purchase this kind of art do so, not for purposes of investment but because it has a symbolic and historic importance.

---

<sup>13</sup>Weinbacher, Dr. Hans, Art at Auction 1970-1975.

### CHAPTER III.

#### CULTURAL PROPERTY LAWS

It is difficult to judge the extent of the antiquities markets because reports indicate that there is a staggering amount of objects that leave the countries of Egypt, Greece, and Rome each year through underground channels and through smuggling.<sup>14</sup> This would indicate that there is still a very active market even if it is based on illegal activities. The prices for these smuggled pieces are probably much higher than what the auction prices indicate because of the high risks involved and because much more desirable works can be obtained. The original countries, of course, wish to keep the best examples and most rarest pieces of ancient art for their own national collections. The punishment they inflict on smugglers now is usually up to five years in jail often combined with a heavy fine. But because these governments often cannot effectively control the illicit activities, many very exceptional examples are introduced into the market. If the governments of Egypt, Greece, or Italy do find the smuggled object in the possession of anyone within or without of these countries, they have the right to repossess the antiquity and are under no obligation to reimburse anyone for their expenses. This has not appeared, however, to discourage corrupt activity. If reports from authorities are correct,<sup>15</sup> the amounts of money used to bribe excavation workers or buy objects on the black-market have been as high as \$15,000 in 1980

---

<sup>14</sup>This information is based on conversations and correspondence with Dr. Herman Keinast, archaeologist of the German School of Archaeology; Dr. Costantine Tsakos, archaeologist of the Greek School of Archaeology; and Dr. George Mylonas, President of the American School of Archaeology and Director of Archaeological Activity in Greece.

<sup>15</sup>Duboff, Leonard, *The Desk Book of Art Law*, Federal Publications, 1977; Statistics for the Archaeological Institute of America, published yearly in the AIA periodical.

before the artifact has ever left the country! It would be a logical conclusion that the objects would be sold again for a much higher price in another country and that the smuggler knows that he has dependable clientele, otherwise he would be unwilling to take such risks.

It is next to impossible to trace who these collectors are unless they are caught red-handed. But at present it is doubtful if many, except for a handful, of these collectors believe that the objects are beautiful simply because they come from a period where life and men were superior. Today, advancing industrialization and technological developments have but eliminated any romantic urges to revert back to a utopian "golden age." Ancient art has lost the symbolic attraction it possessed for many centuries. Art in general has changed drastically in the late twentieth century and there is a tendency to avoid works of art which are based on the classical principles of "no more and no less." Lack of subject matter and all psychology is another indication in modern art of a neutral, essentially anti-romantic outlook. If there is a large market today in naturalistic and more traditional forms of art, it is because these pieces of art are considered a wise investment with a huge appreciation potential. This potential seems to be fairly low in ancient art and might be partly due to the lack of provenance on these pieces compounded with the fact that very few pieces can be attributed to specific artists. The absence of this concrete information makes most pieces less desirable.<sup>16</sup> Possibly the reinforcement of certain cultural property laws has also stifled the antiquities markets somewhat.

---

<sup>16</sup>I am not considering the tax advantages in donating Greek antiquities to museums as a factor because the value of all art objects is increased because of this and not exclusively the value of ancient artifacts.

The right to spoils has been traditionally regarded as inherent in the rights of the victors in war. There have been some instances throughout history, however, when a country or a leader considered it a duty to return cultural property removed from a country in time of war or colonial occupation.<sup>17</sup> At the Congress of Vienna in 1815, the victors of the Napoleonic Wars decided to compel France to effect one of the first large scale restitutions recorded in history.<sup>18</sup> The First World War put this precept to the test when in the Treaty of Versailles, Germany was compelled to return to France those works of art that had been removed not only during the recent conflict, but also during the 1870 war. The Peace Treaty of Riga (1921) laid down the principal of the restitution of cultural property removed from Poland since 1772. Similar decisions were made at the end of the Second World War.<sup>19</sup>

Not until the present day, however, has the problem of a restitution been approached concerning smuggling and illicit trading in times of peace. We will now explore the recent efforts and attempts to curb these activities and will examine a few case studies in which precedents about international trading of art objects have been decided. Although no actual precedent has been made regarding a case of Egyptian, Greek, or Roman antiquities the international laws which apply to some of these cases should apply everywhere.

---

<sup>17</sup>"Cultural Property" has been defined by the Director General of UNESCO, Amadou-Mahtar M'Bow, in 1970 as "any object having a fundamental significance from the point of view of the spiritual values and the cultural heritage of the people." UNESCO, 1970.

<sup>18</sup>Wheaton, Henry, Elements of International Law, Volume 1, F.A. Brockhaus, Leipzig, 1852, p. 15.

<sup>19</sup>Rollet-Andrienne, Louis-Jacques, "Precedents" Museum, March 1980, p. 88.

For at least the last decade or so, the art market has been overlaid with complex international, moral, legal, and archaeological issues. Charges of plundering for the market's sake, or irreversibly dismantling national artifacts or heritages and other offenses have often initiated heated arguments as well as legislation in the United States and around the world.

There have been many attempts throughout history to solve these problems, as briefly reviewed above. But the most comprehensive attempt has been the UNESCO convention in 1964 when a complete doctrine was proposed to introduce measures which should be adopted at government levels and which are aimed both at preventing further loss of cultural heritages and at the return of cultural property to its country of origin. Non-government organizations are also making attempts to combat illicit trading in cultural property. The International Council of Museums (ICOM) launched a campaign among its members in the 1960's to actively promote and support as a professional specialist body efforts to reconstitute dispersed heritages.

Illicit trading is still, today, the most real threat to the unity of the cultural heritage of nations. There was international recognition a few decades ago of the size of the problem of illicit trading. Noting the paradoxical fact that museums, which are public institutions of science, culture, and education, can acquire objects that are known to be of doubtful origin from the moral viewpoint, ICOM drew-up and published a document of the ethics of acquisition.<sup>20</sup>

---

<sup>20</sup>International Council of Museums (ICOM), Ethics of Acquisition, Paris, ICOM, 1971, p. 8.

The adoption of a international code of ethics and of the legal machinery to back it up will not, of course, be enough to put an end to the illicit trading in cultural property. In order to tear out the evil completely, repressive measures taken by national police forces and by Interpol will have to be accompanied by adequate control measures. Each country should assume responsibility for the security of its archeological sites, the movable cultural property in its museums, and its private collections.

Unfortunately, some nations have not yet realized that the protection of their cultural possessions should be based on adequate and realistic legislation as well as on the provision of the corresponding necessary means — technical, administrative, police, and customs. Many times, even this is not enough. In fact, the countries which have very rigorous legislation prohibiting any unlawful export of their cultural heritages are impoverished by illicit trading.<sup>21</sup> In spite of this, little by little, international authorities are making progress in the fight against illicit trading and it should not be forgotten that this is the most influential factor in ensuring the integrity of heritages.

It should be remembered however, that means to encourage an exchange of objects for exhibitions between nations should be pursued. This could be accomplished through the cooperation of the museums of the world organizing international exchanges so that the entire world can be exposed and educated about the different art and antiquities which have been created by different nations. These exchanges could be arranged on the basis of a long term loan and could definitely help facilitate international good-will and understanding.

---

<sup>21</sup>Montreal, Luis, "Problems and Possibilities in Recovering Dispersed Cultural Heritages," Museum, March, 1980, p. 94.



The instances which have resulted in prosecution of smugglers and people accused of art theft have brought to light the ambiguities contained in the ownership laws of various countries. Some of the difficulties were confronted by the court in the case of United States vs. McClain. In this case five individuals were arrested for smuggling U.S. \$200,000 worth of pre-Columbian artifacts from Mexico into the United States. The difficulty with this particular case was that the United States court was forced to rely on Mexican law to determine the status of the objects involved. During the course of the trial, the American Association of Dealers in Ancient, Oriental, and Primitive Art filed a brief as amicus curiae. It argued that items which may have been exported illegally from another country are not stolen property within the meaning of U.S. law. The meaning of the words "stolen property" should not depend on another country's law since this would inject uncertainty into a penal statute. Not only would uncertainty be introduced but also every collector, dealer, museum, and gallery would be guilty of a crime. The importance of the McClain case is that it was the first case to rely totally on foreign law to determine the status of the objects involved. The interpretation and subjectivity forced on the judge in a case such as the McClain case were so questionable that a reversal to the decision was made in 1977 and a simpler reprimand by the judge was the result instead of a charge of felony.

One of the most widely publicized cases about dubious ownership occurred in 1973 when Thomas Hoving, the then director of the Metropolitan Museum of Art in New York, announced the acquisition of a twenty-five thousand year old Greek vase signed by the famous painter Euphionios and the potter Euxitheos. Both Hoving and the curator of Greek and Roman art declined to discuss details about the acquisition of the vase, a calyx krater used for mixing wine and water at banquets. The official story

was that it had been in a private European collection since before World War I. Later it was disclosed that the vase was sold to the Metropolitan by Robert E. Hecht on behalf of an Armenian named Sarrafian. This gave rise to objections from the Italian government that the piece had been recently smuggled out of Italy. Sarrafian claimed that he inherited the vase from his father and that it was in pieces when he sold it. The piece, now in the Metropolitan, shows little signs of breakage and is almost completely intact.

The confusion as to stories and claims in this incident caused the Italian government to drop the charges and the vase remained in the United States. The United States government did nothing to alter or investigate this case and basically ignored the Italian governments accusations. In other words, the United States government did not acknowledge the cultural rights of other nations.

When one considers the fact that the Metropolitan Museum spent more than one million dollars on the vase, it is understandable that it did not want to lose the object or to have it disclosed that perhaps the object came from dubious sources. This example of a large sum of money being spent on art illustrates the reluctance on the part of collectors to want strict laws about cultural property enforced if no reimbursement is to take place.<sup>22</sup>

An interesting precedent was recently sent which may be an example for the entire American museum establishment. This case involved a large of group of important pre-columbian murals valued at about one million dollars in the

---

<sup>22</sup>St. Louis Post-Dispatch, February 25, 1973, p. 5B.

M. H. DeYoung Museum's possession. The national institute of anthropology and history (INAH) in Mexico City objected to the murals being in the possession of a United States Museum. After extensive litigation and discussion it was agreed that half of the Mexican murals would be returned permanently to Mexico while the other half would be on a exchange loan basis to the DeYoung Museum with both institutions and countries being responsible for the restoration and conservation of these pieces. In this particular instance, the entire agreement was made outside any court in Mexico or the United States. Perhaps more cooperation among artistic and preservation institutions internationally might result in agreements which are reciprocally advantageous.<sup>23</sup>

In addition to export restrictions and museum cooperation, another means of controlling illegal passage of cultural property is through the use of import barriers. Usually, it is not illegal to bring in a work of art even if it has been illegally obtained from another country. One solution to this situation is to charge import duty on works of art, or to make it mandatory that all works of art be declared and export permits shown to the customs officer. A case where something of this nature occurred, involved the curator of the Boston Museum in the early 1970's. He exported a painting by Raphael illegally from Italy and did not declare it at the United States customs. This violation of American customs law, and not the violation of any Italian law, resulted in the return of the painting to Italy.

From these above examples, it is evident that all countries should have laws restricting illegally obtained art objects from being imported as well as exported.

---

<sup>23</sup>Braun, Barbara, "Subtle Diplomacy Solves a Custody Case," ArtNews, 81 (Summer, 1982): 42-45.

There has been a startling rise in art smuggling and thefts all over the world. The Italian government has estimated that in Italy alone some \$50,000,000.00 worth of art treasures are stolen or taken illegally from the country each year. Interpol statistics indicate a rate of increase of art thefts throughout Europe. Between 1971 and 1972, the theft rate grew by 14% and it continued to escalate.<sup>24</sup>

There are several solutions which would involve the altering of the general rule of no import restrictions. The importing nation could refuse to admit works of art illegally taken from another country of dubious origin. They might require specific documentation in order for the work to be eligible to be admitted. This is a simple solution because it is unilateral. Some countries, such as Canada, have restrictions for certain categories of art which have a tendency to be stolen or smuggled.

Some countries will agree to return illegally exported items to the original country only if the country of origin has a reciprocal provision. These arrangements are not treaties and therefore are not entirely binding. The most satisfactory solution would be a concrete treaty between all nations concerned with the preservation of each country's cultural property. Treaties, however, require long negotiation and agreement by all parties. Many international treaties have been adopted by various countries with some success. The United States and Mexico have had a treaty since 1972 that states that any person bringing an artifact into the United States without the proper permits would be guilty of a felony. This treaty links the American import laws to the export regulations of Mexico and encourages cultural exchange. It is more

---

<sup>24</sup>Duboff, Leonard, The Desk Book of Art Law, Federal Publications, Inc., Washington, D.C., 1977, p. 79.

flexible than a strict restriction of all Mexican artifacts. It also specifically states that a civil action in the federal district court by the United States Attorney General is necessary to initiate the procedure for the return of the art object.

The UNESCO Convention of 1970 dealt specifically with the problem of illicit import, export, and transfer of cultural property. Only twenty-five nations have participated in the UNESCO Convention. The United States is still in the process of ratifying the UNESCO Convention in Congress. There has been heavy lobbying against the Convention by the American Association of Dealers in Ancient, Primitive, and Oriental Art. If the United States does ratify the Convention, it will be the first major importer to do so, since the other nations involved at present are primarily exporters. This presents problems because the participation of the United States in the Convention might merely cause the illicit traffic to go to another country or even further underground.

In making a judgment about the desirability of international regulation of the art market, one must remember that each country might have conflicting interests. Each country's wish to protect its own cultural property must be balanced with flexibility in the laws of free trade and movement of cultural objects. It might also be the case that overly restrictive laws would merely force the entire market underground instead of curbing the illegal activities or protecting any cultural properties. It would seem to be more desirable to have flexible enough rules so that the movement of art objects can still be monitored on the open market in contrast to black-market activities. The best way to handle this would be to take into consideration the opinions of collectors, dealers, museums, and authorities in various fields of art. The agreement reached between the Mexican authorities and the DeYoung Museum in San Francisco would

seem to be a happy example of this kind of cooperation. After long discussions and negotiations, perhaps an international agreement might be reached which would protect the majority of interests.

## CHAPTER IV.

### GRAPHIC PORTRAYAL OF TRENDS IN THE ART MARKET

There has been a noticeable trend in the art world recently to equate personal property, fine arts and collectibles with the same category as investing in stocks for large corporations. Because of the equation, many firms, dealers and auction houses have made a much publicized display of the fact that fine art is as good as, if not a better, an investment than real estate or perhaps investing in stock or putting your money into bonds or the money market.

The most notable attempt to show the value trends in the art market graphically was initiated by Sotheby Parke Bernet, Inc., the largest auction house in the world. In the fall of 1981, this auction house publicized its index of price indicators in fine arts and antiques. The index is updated weekly and covers twelve specific areas of the art market. These areas have been chosen because they are the largest in terms of volume of all the different and diverse categories that Sotheby Parke Bernet offers for sale. A composite index, which is published monthly, indicates the results of the twelve individual sectors and claims to give a feel of current trends in the art market. (See page 27a.)

The index has been criticized repeatedly by dealers and collectors. The main objections are that this index does not indicate the quality of the works involved and that it is impossible to chart items which are unique and one-of-a-kind and treat them as if they were just so many of the same types of stock of IBM for instance. In order to make a judgment as to whether these objections are valid or not, an analysis of the Sotheby Parke Bernet index will be attempted.

# Charting the Markets

An analysis of recent price trends in key markets, compiled by Sotheby Parke Bernet

FOR ALL INDEXES, SEPTEMBER 1975 = 100.

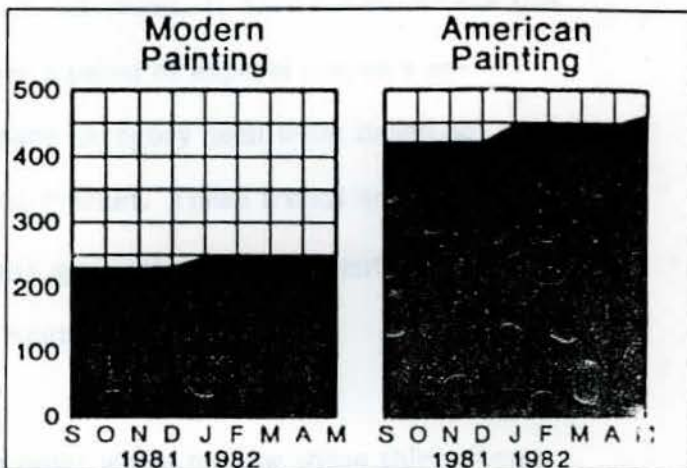
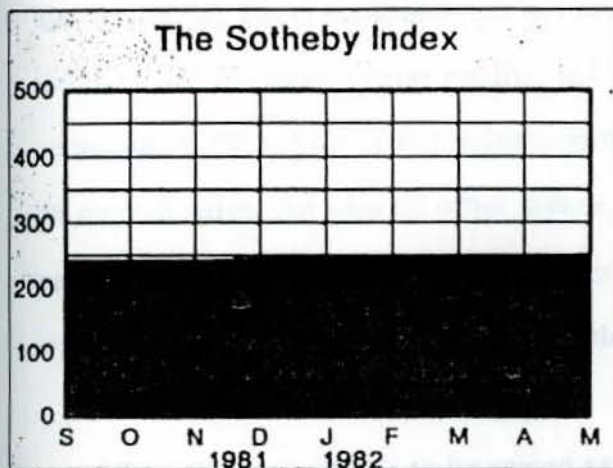

©1981 & 1982 SOTHEBY PARKE BERNET INC. REPRINTED COURTESY OF BARRON'S NATIONAL BUSINESS AND FINANCIAL WEEKLY.

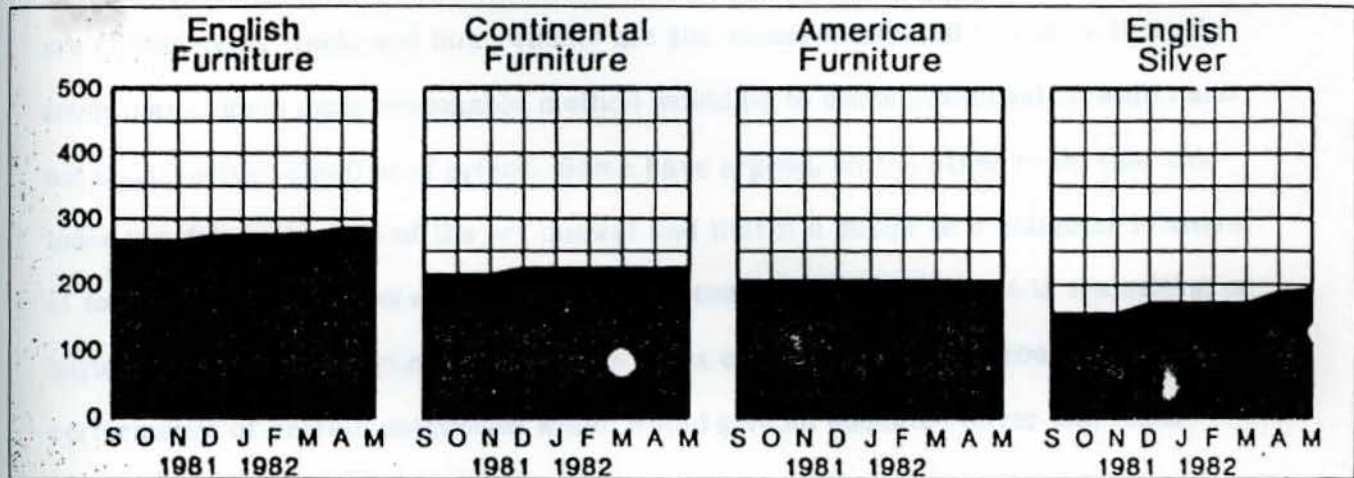

Little changes within the Sotheby Index on its week-to-week charting, and when the numbers do move, they most often indicate a market upswing. Antiques are rarely discounted, so a drastic swing of non-sales at auction would seem to be needed before the index's numbers decrease.

This puzzles Philip Colleck, venerable London and New York dealer in English furniture, who with a benevolent eye on the "computer," tried to understand how his specialty has fared well.

Sotheby's reported after a March sales in London that pieces of good quality being sold out of private collections for the first time had fetched good prices, particularly in sales to dealers. Sales in April both in London and

New York were more mixed and didn't affect the Sotheby's Index.

Mr. Colleck worries that complaints made of other financial indices—that their universes may be skewed by too small a sample—is at play here. "A few items can upset all those figures," he said. "I'm sure Sotheby's . . . used figures to suit their purposes. We have the same situation of a few pieces promoted by a few dealers, and they go berserk [the pieces sell easily] and the general items don't do too well. The graphs don't reflect, both over in London and here in the States, that there's been a reasonably severe drop in business this year. Nobody likes to say that, but I'd say in general, in the middle class, there's been a drop off in values that if it continues, will have an effect

on prices."

Mr. Colleck said dealers weren't as active as in the past at the April New York auctions, which were marked by a few lots that brought exceptional prices. Dealers are staying away from the more ordinary merchandise, and private collectors are out-bidding them for the merchandise that provides the headlines. □

—Mark Westerbeck

The data reflected in the Sotheby Index are based on results of auction sales by affiliated companies of the Sotheby Parke Bernet Group and other information deemed relevant by Sotheby's. Sotheby's does not warrant the accuracy of the information reflected therein. Nothing in any commentary furnished by Sotheby's nor any of Sotheby's indices is intended or should be relied upon as investment advice or as a prediction, warranty or guaranty as to future performance or otherwise.



There are many questions about the methodology that Sotheby's uses in order to compile these graphs. The method used is that there are thirty items chosen to represent each of the twelve categories, or "market baskets." One would assume that the figures are based solely on Sotheby's sales, which, of course, are exclusively auction sales. That, apparently, is not Sotheby's intention. It does not even base this index on actual auction sales results, but rather a panel of experts makes a re-appraisal of the values of the objects sold in each category each week based not only on current sales, but also on other trends in the market. These trends are not particularly made public to the observers of the art market, nor is it entirely explained what objects are within the twelve individual sectors.

The major questions to be raised at this point would be how these thirty items are chosen every week, and how reliable are the values attributed to them. It would seem that a much more reasonable method would be to choose actual sales results and not a subjective selection of prices. Some have argued, on the other hand, that this index is a fair indication of the art market and that if a dealer or a collector is aware of some of the drawbacks and is able to make some quality judgments in the selling or buying of a particular art object that this index can at least give a broad idea of the performance of certain categories which would give an educated buyer and seller certain boundaries within which to work.

The other major question as to the results of Sotheby's index is that these results and the prices reflected by the experts based only on the trends at auction. The auction sales account for a large part of the market and certainly enjoy the major part of the publicity of the market but it is sometimes not a fair indication of what is happening in the more reasonable, more steady, less heated retail front.

Given this background in the methodology of the compilation of the Sotheby index, this project will attempt to compile the data from a limited interest art market category, antiquities, to see whether by using actual sales results, a market trend and analysis can be achieved. A limited interest category has been chosen because the volume of objects sold is more manageable.

The methodology employed in this compilation was to accumulate sales results from auction houses and retail outlets, when available, in the categories of the Egyptian, Greek and Roman ancient art. These categories were further broken down into sculpture, ceramics, and glass, the major art media which are relevant to all three places of origin. It should be noted at this time, however, that certain major art forms such as Egyptian mummies, have been omitted because they were only found in one category. If a more detailed analysis were undertaken, a much more comprehensive and extensive list of data should be obtained. (See Appendix I, Antiquity Sales Results, May 1977 through February 1982, pgs. 43-67.) Another fact should be noted at this time, and that is the major drawback to working with a small interest category such as antiquities this is that the information available for sales results be it auction or retail, are slimmer and slimmer the further back in time they can be traced. This is because there is little demand for this information and most reference sources at least in the Midwest, prefer to open up the space utilized by the small interest information for the larger interest information categories.

The information given in Appendix I has a certain format. The first category is Egyptian Sculpture is the next topic. Under this category, the medium that the sculpture is made out of is the first consideration. Then the title, then the period, the size, a brief description, and the provenance, or where the object came from, is

included. Then the auction or retail house is listed, the place where the auction or sale took place, the date and the value in the currency in which it was sold. This foreign currency value is then converted into U.S. dollars using the exchange rate on the date of the sale. Other information which will be included in more recent sales was impossible to obtain for the earlier sales. This unavailable information was, for instance, the estimated cost, the extent to which an elaborate display was made in the auction catalogues, and the condition of the piece. This is because the earlier information was obtained solely through publications such as Dr. Winebacher's Art at Auction which merely lists and sometimes gives a small reproduction of the object, a minimal description, and then the price for which it sold.<sup>25</sup> This information oftentimes is not enough to analyze exactly what occurred at that particular sale, or to analyze whether the estimate was higher or lower than the sales result. This lack of information is alleviated for the 1982 data.

After a fairly extensive list of information was compiled for the time period from May 1977 to February 1982, the price results were computed and an average price for each year in each category was displayed on a bar graph and then on a line graph (see Appendix II, computer printouts A and B). This type of bar and graph analysis of average prices is a common technological asset when considering industrial and manufacturing trends. But for some unknown reason, these kinds of analyses are not being utilized, or at least made public, in the fine arts field. The total dollar amount for each year was then graphed on pie graphs (see Appendix I, computer printouts C-G).

---

<sup>25</sup>Sotheby Parke-Bernet and Christie's Auction Catalogues.

At this point, several observations can be made from observing the graph results. One is that Egyptian art rose in 1977 and 1978. Roman art made a huge leap in 1979 and Greek art remained relatively stable. These indicators were hints that a more detailed and thorough investigation should follow. In reviewing the sales results, i.e., the extensive lists of information which were not considered in these graphs, the writer observed that several major world records were made in Egyptian art in 1977 and 1978. In 1979, one Roman piece of glass, which was one of its kind and extremely rare and desirable, sold for over \$1 million. Another piece of Roman glass sold in the same year for \$171,000 (see Appendix I, page 55).

It is at this point that the appraiser and observer of these bar, line and pie graphs should realize that the prices alone can sometimes be unreliable indicators. The exaggerated leaps and dips caused by one record-breaking sale, or lack of sale, can give a completely distorted picture of overall trends in the art market. After weighing the factors relevant to the market, and comparing other more average pieces from the different categories, it was decided that the exaggerated high prices, or what will be termed "freak" sales results will be eliminated since they do not reflect any past or future trends in the Roman or Egyptian markets. Any other high prices which were not felt to represent a consistent trend were also eliminated. It should be noted at this time that the observer of these trends over the past five years has had the advantage of hind- and fore-sight, as it were, and can make that rather subjective judgment about whether these high record-breaking prices were "freak" results or were going to set a trend for even higher prices. Therefore, the graphs H-V do not include these "freak" prices. However, this information is included in Appendix I.

These decisions are subjective judgments made by the researcher. Yet, they should be based on all the facts available. This is why it is extremely important to include in the initial data collecting, the information of medium, subject matter, period of the item, short description, provenance (if any), the place of sale (that is, the auction house or retail outlet), the geographic location, the date of the sale, the estimate (if available), and the currency in which it was sold. The importance of each of these individual categories will be analyzed in a later section of this project.

After elimination of the exaggerated prices, further graphs were compiled. The total dollar amount per each quarter is shown on graphs H-J (see Appendix II, p. 65). In observing these graphs, it would appear that each category was extremely volatile with high peaks and valleys which oftentimes dipped to zero. The average dollar sales by quarter of each country of origin would, of course, show corresponding trends. (See Appendix II, computer printout graphs K-M.)

At this point, it should be observed that knowledge of several factors which have an impact on the graphed results of these sales is imperative. One major factor is the fact that for unknown reasons, the sales in antiquities occur for the most part in May, June, July and in December of each year. This would explain the deep valleys in the graph which dip down to zero. A more realistic graph would be one which took into account only the sales which actually took place and not the lack of sales altogether. Another very important qualifying factor is the fact that in the 1970s, there were several major attempts to initiate cultural property laws. These laws as stated above were originally encourage by the UNESCO convention of 1970 and were further emphasized in several major legal decisions. These laws are designed to curtail the illegal export of national treasures and antiquities from many countries, including

Egypt, Greece and Italy. The fact that the country of origin has the right to confiscate the item without reimbursing the owner in any way would, of course, cause many investors in antiquities to hesitate purchasing an item if there was a possibility of a total loss. As a result, unless the provenance of the particular piece was perfectly clear, or unless the piece was insignificant enough so that a country would be indifferent, the sales in this area go unrecorded and are usually transacted on the black market. Price results from sales of this nature are impossible to obtain and of course do not really constitute a part of the acknowledged market. This situation might explain the culminating overall dip in the antiquities market which began to show itself most markedly in late 1979. Once these factors are brought to the attention of the observer, a deeper understanding of the graphic portrayal of the antiquities market can be obtained.

Some relevant information, however, can be gleaned from these graphic analyses. An analyst can further utilize the data available by determining a correlation between the total dollars sales per each quarter and the number of items sold. This would immediately indicate that there were some quarters with no sales whatsoever and it would also give a hint as to whether one item went for a high value or whether many items went for a more average value. This information would be useful in determining the market in each category in that an observer could see what the supply of the items was, and what would be a rough expectation of the sale value of those items. To give a truly realistic picture of this information, however, a much broader base of data would have to be supplied. As stated above, this is extremely difficult in a small interest category where past information is usually not available to the general public. This would be an extremely valid and useful goal, however, for other areas of larger interest. (See Appendix II, computer printouts graphs N-P.) In

conclusion, the total dollar results as well as the number of items sold in each category can be graphed comparably to show if there is any possible correlation and to make a judgment from these trends as to which market would make the best investment. (See Appendix II, computer printout graphs Q-V.)

## CHAPTER V.

### DATA COMPILATION AND PROCESSING FOR VALUATION OF FINE ARTS

In order to make full use of today's technology in judging the art market, one must, first of all, have some exposure to and knowledge of art. One must also realize that each one of these items of art is one of a kind and that at each sale certain qualitative judgments are made by the buyer and seller which influence greatly the sales results. A broader comprehensive list of sales data would help to show some of these comprehensive judgments. The next section of this project will be to take more recent sales data and to utilize the word processing technology to break down some of the characteristics of each item sold and compare them with other similar characteristics belonging to other items so that perhaps some feel for an overriding comparable market might be more obvious with the individual factors taken into consideration.

A classifying system will be attempted according to quality and desirability of each piece. This classifying system will take into account all the factors: the school or artist, geographic origin, the date medium, the subject matter, the size, the rarity, the condition, the provenance, and where the item was sold, which combine together to create a value for each item. The system would be, by its very nature, subjective, but would be an invaluable service to anyone with a reasonable awareness of the market.

In order to make any sort of data compilation of fine arts relevant, certain necessary information must be included. This information will be subdivided into various categories.



**School or Artist:** In antiquities artists were basically unknown. Whenever an artist or a school is known, however, prices seem to escalate.

**Geographic Location:** In antiquities, the most major categories would be Egyptian, Greek or Roman.

**Period:** Periods in antiquities usually indicate either the dynasty in Egyptian Art, the era or period in Greek Art and what reign of what emperor in Roman Art. The period and style usually go hand-in-hand. A certain style will indicate a specific period. This category can affect the value since certain eras and dynasties are more desirable than others. Works of art, for example, from the classical age of Greece (Fifth Century B.C.) would be more desirable than artifacts from the late Roman Empire. Pieces from the "dark ages" of the Mycenaean Period, on the other hand, do not have a high attraction. Once the style, period and geographical identification have been accomplished, the next major category should be Medium.

**Medium:** The medium in antiquities is usually broken down into sculpture, ceramics or glass. The sculpture is further broken down into bronze sculpture or marble sculpture. The ceramics consist usually of different forms of functional ceramics or terra cotta votive figurines. The glass is a category usually exclusive to the Roman period, but is sometimes found in earlier periods. There are no variations in that medium. Some media such as bronze and gold have intrinsic metal value in their own right. This further enhances the value of any piece of sculpture made in either one of these media. Sculpture, in general, is a more desirable category than either ceramics or glass, usually because of the larger dimensions. Oftentimes in sculpture the human figure is depicted which is the most desirable and most high priced of all the subject matter. The medium of ceramics, although desirable, is usually much lesser priced because the making of ceramic artifacts was prolific in ancient times. Artifacts made of glass were usually prolific but because of their

delicate nature, are more rare than the ceramics. Because of this, they bring relatively high prices for their size.

**Subject Matter:** The next major category which should be included in the data information is the category of subject matter. In antiquities, the depiction of the human figure or a god in human form is the most desirable type of sculpture, and also, of design in the glazing of ceramics. Certain types of animal forms, especially cats in Egyptian art, are very collectible and bring higher prices. In Egyptian and Roman sculpture, the identity of the Pharaoh or Emperor gives added attraction and therefore added value.

**Dimension:** Size and measurements must always be included in any information about an art object. Antiquities are no exception. Size can play a definite role in the desirability of a piece. For example, a large, life-size marble statue of a god can command higher prices than a smaller marble statue with a similar subject matter.<sup>26</sup>

**Rarity:** The subject matter, size, medium, period, geographic location, and artist or school all combine to form the category of rarity. In some areas of fine arts, the more typical a piece is, the more desirable it is. In antiquities, however, this is not the situation. If a piece can be proven to be authentic and extremely rare, often record breaking prices are realized. A fine example of this phenomenon occurred in April of 1979 at Sotheby's in London, when a glass cage-cup went at auction for \$1,081,600. This bowl is the only surviving example of its type.<sup>27</sup>

---

<sup>26</sup>Weinbacher, Dr. Hans, Art at Auction 1970-1975. See Appendix I, page 3, Roman Sculpture, items 1 and 4 for sample comparison.

<sup>27</sup>See Appendix I, page 15, Roman Glass, item 1.

**Condition:** Another major category which would be included in the information data would be condition. Condition is an overriding factor in most areas of fine art. Antiquities are somewhat of an exception, however, because of their great age. Usually, pieces which are over two thousand to three thousand years old will have some major age damage. Antiquities oftentimes can be broken into many pieces or have parts missing or have replaced parts. Unless the damage is absolutely major or the repair of poor quality, this does not usually affect the price of antiquities. Glass, of course, is much more difficult to restore or replace and the broken areas are much more obvious. Therefore glass in poor condition is not as desirable.

**Provenance:** One other major category which should be included if available is the provenance of an item. The provenance can affect the value of an artifact drastically. Provenance means the history of ownership of an object. A major sales, for example, occurred at the Spinks and Koller Auction Houses in Zurich on October 16, 1979. This sale was the sale of the Brummer collection of antiquities. This was one of the "world's most impressive collections of antiquities."<sup>28</sup> The prices at this sale were considerably higher because of the fame of the collectors. One other example of provenance playing a major role is the Roman glass cage-cup which was previously mentioned and which sold at Sotheby's in London on June 4, 1979. It was part of the Constable-Maxwell Collection of Ancient Glass which brought a total of \$1,833,811, a "remarkable figure for an area of such limited interest."<sup>29</sup>

**Quality:** The categories described above, the geographic identification and school, the medium, period, subject matter, size, condition, rarity and provenance, combine together to form that nebulous concept, quality. This is a very difficult and

---

<sup>28</sup>Katzander, Howard, L., International Art Market, November, 1979, p. 4.

<sup>29</sup>Ibid.

elusive concept which necessarily becomes subjective. The evaluator must have a deep arthistorical understanding of the object to appreciate the period, geographical identification and rarity. He must also have a knowledge of what constitutes the concept of condition. Moreover he must be sufficiently impressed with the provenance of the piece. In other words, the evaluator must be a connoisseur of the particular area of fine arts he is appraising.

**Rating System:** With these qualifications the evaluator can make certain judgments about a piece and rate its quality. I suggest a code rating of 1 to 10 to indicate the quality of a piece. It should be stressed again, however, that this numerical rating is a result of the combination of the characteristics defined above which cannot be broken down into numerical importance. In other words, the numerical rating alone would merely give a hint to a piece's importance, but would not tell the details. The relative details should be indicated in each category. It should be mentioned that this rating system would be self-contained for each major category, such as Egyptian, Greek or Roman. That is, a "6" in the Roman category would be a "6" for that category alone and could not or should not be compared to any other category. This point becomes especially important to the appraiser. It should be stressed that cross-cultural or cross-geographic comparisons are invalid.

A suggested system for this rating would be that numbers one to three would apply to extremely undesirable or poor works of art. Average items or items which are usually found in great quantities would range in numbers from 4 to 6. Exceptional items, highly desirable artifacts or extremely rare pieces would range in numbers from 7 to 10.<sup>30</sup>

---

<sup>30</sup>See Appendix III - Sales Results and Rates for rating system examples.

After a rating system has been established, this information can be fed through a processor with various sales information. This information would consist of identification of the auction house or gallery where the sale took place, the geographic location of this sale's establishment, and the date of the sale. The geographic location of the sale should be noted with attention by the evaluator since tastes and preferences vary according to locale. In antiquities the trends seem to indicate that there is a marked willingness to pay higher prices in Europe than in the United States. This would reflect the European emphasis on classical education and the heightened interest in archeological activities.

At this point the auction house estimate should be given. If this estimate is given in a foreign currency, this should be translated into U.S. dollars at the rate of exchange of the day of the sale. The sales results would be the last item included with the foreign currency value first and then translated once again into the U.S. dollar rate of exchange.

Once this information has been fed into a processor, a recall system according to the major categories of Egyptian, Greek, Roman, sculpture, ceramics or glass can be utilized. The rating system would be merely a hint to the appraiser searching for comparables. He can evaluate the rating of the item he is appraising and compare with the others which are included in the comparable data on the processor print-out. The comparable data with a similar rate would be the appraiser's comparable market. The time saving factor with this computed recall system is tremendous. Eventually the computer could be a terminal into which data is fed from across the country and around the world. The volume of the comparable market would thereby increase and evaluations based on this market would reflect a broad base of similar items.

## CHAPTER VI.

### CONCLUSION

This report has considered a single subject matter, antiquities, from several diverse angles. A historical review of the value of antiquities was used as a base to further comprehend recent developments in the ancient art market. These developments have been directly affected by cultural property laws and restrictions which were given overall consideration in this report. No consideration was given to the ever-present problem of fakes and forgeries of antiquities, which falls outside the scope of this study.

The paper then proceeded to analyze the market trends in antiquities over the last five years in order to obtain a deeper understanding of current developments. The graphic portrayal of the market in antiquities was introduced to emphasize how helpful and how misleading such graphs can be. An appraiser, collector, or investor should be made well aware of the futility of utilizing these graphs without a deeper understanding of qualitative information regarding each item and every sale.

To help the appraiser become more aware of this qualitative information, a methodology of data compilation was introduced so that all the necessary factors can be made available in one place in a readable manner. To summarize the quality of each item, a rating system was introduced.

It is the objective of this report to utilize the broad analysis of a limited interest category in fine arts, such as antiquities, in order to illustrate a methodology which could be applied to more active areas of the art market. Only if the methodology is

applied to more than just a few areas of fine arts would it be of interest to the majority of appraisers. And only then would it be cost effective to introduce a fully computerized central information system. This system could be based on a central terminal which would store the data input from appraisers throughout the world. In exchange, these appraisers would have access to the most complete and accurate comparable market data available.

APPENDIX I

ANTIQUITIES SALES RESULTS

May 1977 through February 1982

Object	Description	Buyer	Price
Figurine	Small, light-colored, possibly terracotta or stone, figurine of a seated figure, possibly a deity or royal figure, with a prominent headdress or crown. The figure is shown in a seated position, facing forward.	Christiana, London	£1,200
Figurine	Small, light-colored, possibly terracotta or stone, figurine of a seated figure, possibly a deity or royal figure, with a prominent headdress or crown. The figure is shown in a seated position, facing forward.	Christiana, London	£1,200
Figurine	Small, light-colored, possibly terracotta or stone, figurine of a seated figure, possibly a deity or royal figure, with a prominent headdress or crown. The figure is shown in a seated position, facing forward.	Christiana, London	£1,200
Figurine	Small, light-colored, possibly terracotta or stone, figurine of a seated figure, possibly a deity or royal figure, with a prominent headdress or crown. The figure is shown in a seated position, facing forward.	Christiana, London	£1,200
Figurine	Small, light-colored, possibly terracotta or stone, figurine of a seated figure, possibly a deity or royal figure, with a prominent headdress or crown. The figure is shown in a seated position, facing forward.	Christiana, London	£1,200
Figurine	Small, light-colored, possibly terracotta or stone, figurine of a seated figure, possibly a deity or royal figure, with a prominent headdress or crown. The figure is shown in a seated position, facing forward.	Christiana, London	£1,200
Figurine	Small, light-colored, possibly terracotta or stone, figurine of a seated figure, possibly a deity or royal figure, with a prominent headdress or crown. The figure is shown in a seated position, facing forward.	Christiana, London	£1,200
Figurine	Small, light-colored, possibly terracotta or stone, figurine of a seated figure, possibly a deity or royal figure, with a prominent headdress or crown. The figure is shown in a seated position, facing forward.	Christiana, London	£1,200
Figurine	Small, light-colored, possibly terracotta or stone, figurine of a seated figure, possibly a deity or royal figure, with a prominent headdress or crown. The figure is shown in a seated position, facing forward.	Christiana, London	£1,200
Figurine	Small, light-colored, possibly terracotta or stone, figurine of a seated figure, possibly a deity or royal figure, with a prominent headdress or crown. The figure is shown in a seated position, facing forward.	Christiana, London	£1,200



PIECE	DESCRIPTION	SELLER	SELLING PRICE
Egyptian Sculpture	Bronze figures of a cat; 22nd-30th Dynasty (946-342 B.C.); 4-15/8" height; seated, stylized build, narrow head with long eyes and high pierced ears, engraved and with traces of gilding; bronze with greenish black patina; ex collection of Greta S. Heckett	SPB, New York; May 21, 1977	\$17,500.00
Egyptian Sculpture	Gilt-bronze figure of a seated cat; Late Period (712-30 B.C.); 17-5/8" (damaged); large coffin, paws forward, the separately cast massive asymmetrical head with one amber eye remaining; ex collection of Greta S. Heckett	SPB, New York; May 21, 1977	\$20,000.00
Egyptian Sculpture	Bronze figure of Horus; 26-30th Dynasty (664-342 B.C.); 7" height; large figure of falcon god, patron of the god Horus, with wings crossing over the tail, eyes and eye markings once inlaid; reddish-brown and green patina; ex collection of Greta S. Heckett	SPB, New York; May 21, 1977	\$ 6,000.00
Egyptian Sculpture	Bronze figure of a lying crocodile; 8th Dynasty; 3 1/2" length; Tail coiled, gold pellet eyes, on a sled and with the prenomen of Amenhotep III; repaired	Christies, London; November 17, 1977	\$10,007.78 £ 5,500
Egyptian Sculpture	Bronze statue of a cat; 26th Dynasty (c. 664 B.C.); 10-3/4" height; ears pierced for earrings; hollow cast with green and red patina	Christies, London; March 16, 1977	\$44,707.00 £ 26,000
Egyptian Sculpture	Green-grey granite statue of the god's father and priest of Amun in Karnak; 26" height; 20th Dynasty (c. 610 B.C.); inscribed on ass sides; excavated in 1896-1897 by Miss Margaret Benson and Miss Janet Gourley from the Temple of Mut in Asher; ex collection Benson	Christie's, London; March 16, 1977	\$189,145.00 L 11,000
Egyptian Sculpture	Limestone head of an Amarna princess from a Boundary Stele; from Tel-el-Amarna; 21" height; ex collection Smeets	Sotheby's, London; November 11, 1977	\$54,600.00 L 30,000
Egyptian Sculpture	Head from a limestone statue; late 18th Dynasty; 6" height; man in curled two-tiered wig wearing false beard	Christies, London; July 12, 1977	\$12,042.80 L 7,000

PIECE	DESCRIPTION	SELLER	SELLING PRICE
Egyptian Sculpture	Black granite head of a statue of Sekhmet; 28" height; 17th Dynasty	Christie's, London; July 12, 1977	\$20,644.80 £ 12,000
Egyptian Sculpture	Bronze statue of Winged Isis; Late Period or Ptolemaic; 35.4 cm height (13,8"); bronze with traces of glass paste inlay; wings repaired and partially restored	Christie's, London; November 17, 1977	\$ 9,409.92 £ 5,200
Egyptian Sculpture	Bronze figure of Harpocrates; Late Period; 9½" height; standing, left leg forward, right forefinger to his mouth, wearing the uraeus	Sotheby's, London; November 7, 1977	\$ 7,595.70 £ 4,200
Egyptian Sculpture	Black balsalt head of an official; Late Period; 10¼" height; shaven head and finely carved features; right half of head missing	Sotheby's, London; December 13, 1977	\$24,742.90 £ 13,500
Egyptian Glass	Sandcore alabastron; 5th Century B.C.; 5¼" height; opaque white glass body decorated in maroon with trailed feather pattern, band of maroon at the rim, trailed lug handles	Christies, London; March 16, 1977	\$ 1,891.45 £ 1,100
Greek Sculpture	Marble head of a youth; Hellenistic; 2nd Century B.C.; 13½" height; short curly hair and parted eyes with unarticulated pupils gazing slightly down	Christie's, London; March 16, 1977	\$24,073.00 £ 14,000
Greek Sculpture	Female terra cotta head; Cyprus; 6th Century B.C.; 8" height; traces of colorful decoration; ex collection Smeets	Sotheby's, London; November 7, 1977	\$ 8,185.50 £ 4,500
Greek Ceramic	Black figure neck amphora; Attica; 6th Century B.C.; 16-¾" height; obverse with Dionysus between dancing maenads; reverse with quadriga and warrior; palmettes tendrils and lotus buds at either handle; incised red and white details	Christie's, London; March 16, 1977	\$12,821.25 £ 7,500
Greek Ceramic	Red figure on black stamnos; Etruria; 4th Century B.C.; decorated with scenes from the legend of Achilles; 13" height (33 cm)	Mes. Ader, Picard, Tajan Paris; May 26, 1977	\$16,176.00 F 80,000

PIECE	DESCRIPTION	SELLER	SELLING PRICE
Greek Ceramic	Amphora; Attica; last quarter 6th Century B.C.; 12½" height (31.75 cm); decorated with bearded Dionysus between two satyrs and a young man playing the harp between two women; black figures on red	Mes. Ader, Picard, Tajan, Paris; May 26, 1977	\$ 5,661.60 F 28,000
Greek Ceramic	Amphora; Corinth; last quarter of 7th Century; 15.1" height (38.5 cm); three registers: one with figures; one with flowers & foliage; one with six lions	Mes. Boisgirard, de Heeckeren, Paris; November 29, 1977	\$ 5,160.00 F 25,000
Greek Ceramic	Red figure neck amphora; 5th Century B.C.; 14-¾" height (37.4 cm); painted by the Louvre Centauromachy; obverse with young warrior; reverse with two draped youths	Christie's, London; July 12, 1977	\$12,042.58 £ 7,000
Roman Sculpture	Marble torso of a young man; 1st Century AD; 19.6" height (50 cm); replica of a Greek original form; 5th Century	Me. Renaud, Paris; February 1, 1977	\$ 7,619.00 F 38,000
Roman Sculpture	Marble head of a goddess; Roman 1st Century BC-1 Century AD; 13" height; probably Aphrodite of the type called Sappho after or inspired by a Greek original of the 2nd half of the 5th Century B.C.; thick wavy hair bound twice; found in Central Italy, probably at Tarquinia	SPB, New York; May 21, 1977	\$ 15,000
Roman Sculpture	Marble bust of an Emperor, head missing, probably Flavian; late 1st Century AD; 17½" x 28"; worked for insertion onto a pedestal, wearing cuirass carved in relief with winged Gorgoneion, should strap with lion's head.	SPB, New York; May 21, 1977	\$ 3,850.00
Roman Sculpture	Marble torso of a male; 1st-2nd Century AD; 2'-2-¾" height; standing with his right hand behind his back	Sotheby's, London; April 4, 1977	\$18,912.30 £ 11,000
Roman Sculpture	Marble masculine head; Roman copy of Greek original; 2nd Century AD; 12½" height (32 cm); inspired by Greek sculpture of 4th Century BC; breakage; ex collection Peyrefitte	Mes. Ader, Picard, Tajan, Paris; May 26, 1977	\$13,143.00 F 65,000

PIECE	DESCRIPTION	SELLER	SELLING PRICE
Roman Sculpture	Marble head of the young Caracalla; 2nd-3rd Century AD; 30" ht. (76 cm); Carrara marble; ex collection Peyrefitte	Mes. Ader, Picard Tajan, Paris; May 26, 1977	\$34,373.00 F 170,000
Roman Sculpture	Bronze figure of a young satyr; 1st Century BC-1st Century AD; 1'-8-7/8" (52.8 cm); standing, completely naked, raising his right arm, right leg rests on the tip of the toe; left arm and lower part of right arm missing; some restoration; ex collection Smeets	Sotheby's, London; November 7, 1977	\$16,376.00 £ 9,000
Roman Sculpture	Marble figure of Athena; c. 1st Century AD; 34½" (87.6 cm); standing, wearing an aegis with central Medusa mask; head and arms missing	Sotheby's, London; July 11, 1977	\$ 3,457.00 £ 1,900
Roman Sculpture	Marble male torso; c. 1st-2nd Century AD; 25" height (63.5 cm); right arm remaining	Sotheby's, London; November 7, 1977	\$ 3,821.00 £ 2,100
Roman Sculpture	Marble figure of a youth; c. 2nd Century AD; 17½" height (44.4 cm); upper half of figure of Apollo or Dionysus; standing head with wavy hair; ex collection Lan	SPB, New York; October 21, 1977	\$ 8,250.00
Roman Sculpture	Marble head and neck of a horse; 2nd Century AD; 21" height (53.3 cm); with flaring nostrils and half-open mouth	Christie's, London; July 12, 1977	\$ 6,538.00 £ 3,800
Roman Sculpture	Bronze figure of an emperor; 2nd-3rd Century AD; 10-3/4" height (27.3 cm); probably Marcus Aurelius; standing, bearded face, long hair and deeply drilled eyes; cuirass with acanthus tendrils; ex collection Smeets	Sotheby's, London; November 7, 1977	\$ 9,098.00 £ 5,000
Roman Glass	Bluish-green glass bowl; c. 1st Century AD; 6½" (16.5 cm)	Sotheby's, London; April 4, 1977	\$ 770.00 £ 450
Roman Glass	Translucent green glass cinerary urn; c. 2nd Century AD; 12½" height (31.75 cm); bulbous body on low foot, flat knopped cover filled still with some human bones	Christie's, London; March 16, 1977	\$12,896.25 £ 7,500

PIECE	DESCRIPTION	SELLER	SELLING PRICE
Roman Glass	Byzantine amber glass jar; Palestine; c. 6th-7th Century AD; 7½" height (19 cm); hexagonal; molded in intaglio on each side with a symbol within a dotted border	SPB, New York; May 5, 1977	\$ 4,000.00
Roman Glass	Translucent grey-blue glass flask; 1st-2nd Century AD; 3½" height (8.8 cm); globular body decorated with applied motif.	Christie's, London; July 12, 1977	\$ 275.25 £ 170
Roman Glass	Bluish-green glass flask; 1st-2nd Century AD; 10½" height (26.6 cm); almost spherical body decorated with wheelcut bands of varying thickness	Sotheby's, London; December 13, 1977	\$ 1,319.50 £ 720
Roman Glass	Glass translucent blue-green cinerary urn; 10-3/4" height (27.3 cm); ovoid body with flat vase and an upstanding rim of irregular form	Christie's, London; November 17, 1977	\$ 1,364.70 £ 750
Roman Glass	Dark blue glass alabastron; c. 2nd Century BC; 5" height (12.7 cm); sandcore, trailed bands of yellow; some combed into a feather pattern	Sotheby's, London; December 13, 1977	\$ 1,924.44 £ 1,050
Egyptian Sculpture	Green breccia upper part of a statue of a priest of Khonsu; late period; 15¼" height (13.3 cm); the square-ended dorsal column inscribed with an invocation to Amun and to Mut	Christie's, London; June 14, 1978	\$14,005.50 £ 7,500
Egyptian Sculpture	Bronze figure of a cat; Saite period; 3-7/8" (9.9 cm);	SPB, London; June 20, 1978	\$ 3,300
Egyptian Sculpture	Limestone head of a man; 5th Dynasty (2450-2290 BC); 11.7" height (29.7 cm); probably from the figure of a scribe	SPB, New York; December 14, 1978	\$22,000.00
Egyptian Sculpture	Limestone figure of Kar and his wife Khentetsout; 5th or 6th Dynasty; 58" x 28" (147.3 cm x 71.1 cm); painted brown, black and yellow	Mes. Laurin, Guilloux, Buffetaud, Tailleur, Paris; November 16, 1978	\$69,000.00 F 30,000

PIECE	DESCRIPTION	SELLER	SELLING PRICE
Egyptian Sculpture	Limestone fragment of a servant statue; 6th Dynasty (2290-2155 BC); 19.3" length (49 cm); body bent forward at the waist, the fragmentary arms extended; yellow body; eyes, eyebrows and hair black; white headband	SPB, New York;	\$49,000.00
Egyptian Sculpture	Hollow cast bronze statue of a king on one knee, presenting and offering tablet; late Dynasty XX-Dynasty XXI; 25.7" height (65.2 cm); the inscription on tablet too worn for identification; on wood stand	Christie's, London; November 21, 1978	\$96,975.00 £ 50,000
Egyptian Sculpture	Bronze figure of cat; late period (712-30 BC); 39" height (99 cm); with the eye of Horus engraved on its chest; bronze with greenish black patina	SPB, New York; December 14, 1978	\$14,500.00
Egyptian Sculpture	Alabaster ushabti of King Taharqu; 25th Dynasty (690-664 BC); 32.7" height (83 cm); holding two hoes and two seed sacks	SPB, New York; December 14, 1978	\$ 9,000.00
Egyptian Sculpture	Bronze figure of Wadjet; Ptolemaic or early Roman period; 48.7" (123.7 cm); the scepter of the left hand now missing; the engraved panels with King Amasis offering incense to Horus and Wadjet; verse with the name of the goddess; engraved representation of the falcon god and the signs of the Egypt; restored and repaired.	Sotheby's, London; July 3, 1978	\$37,060.00 £ 20,000
Egyptian Sculpture	Granite head of a man; late New Kingdom/3rd Intermediary Period (1196-712 BC); 8.9" (22.6 cm); eyebrows and cosmetic incised	SPB, New York; May 19, 1979	\$12,500.00
Egyptian Sculpture	Limestone figure of a man; late 5th Dynasty (c. 2350-2290 BC); 31.6" (80.3 cm); striding of a rectangular base with back pillar; smooth kilt; layered wig; remains of red pigment and yellow and turquoise; from the serdab of Wery & Mety at Giza; bought by a European private collector; world record for an Egyptian piece	SPB, New York; December 14, 1978	\$ 280,000
Greek Sculpture	Geometric bronze figure of a horse; 8th Century BC; 1-3/4" (4.5 cm)	SPB, London;	\$ 1,000.00

PIECE	DESCRIPTION	SELLER	SELLING PRICE
Greek Sculpture	Bronze figure of a horse; 7th-6th Century BC; 3½" height (8.8 cm); geometric style; rectangular base of openwork form	Christie's, London; June 14, 1978	\$ 7,469.40 £ 4,000
Greek Sculpture	Geometric Greek bronze bull; 8th-7th Century BC; 1½" (3.9 cm)	SPB, London; June 20, 1978	\$ 800.00 £ 4,000
Greek Sculpture	Marble torso of Aphrodite; 1st Century BC; 7½" (19 cm); standing on a high rectangular base with weight resting on left leg; feet finely carved; himation lifted over right leg	SPB, New York; December 14, 1978	\$ 1,000.00
Greek Ceramic	Terra cotta vase in form of a siren; Sicily; 5th Century BC; 4.8" length (12.3 cm)	Christie's, London; April 24, 1978	\$ 788.13 £ 420
Greek Ceramic	Amphora, Tyrenien; 6th Century BC; multi-colored figures of man and woman	Mes. Laurin, Gouilloux Buffetaud, Tailleur, Paris; November 16, 1978	\$ 8,326.00
Greek Ceramic	Red figure volute crater; Apulia (c. 360-330 BC); 22.3" (56.8 cm); with a woman seated in an Ionic naiskos holding a mirror, flanked by attendants; the other side with two women holding mirrors flanking a grave stele; handles terminating in duck's heads and human masks	SPB, New York; December 14, 1978	\$ 6,400.00
Greek Ceramic	Attic black-figure Chous Oinochoe; (c. 540 BC); 7-3/8" (18.7 cm); painted with warriors; details in red; found Orvieto in the late 19th Century	SPB, New York; December 14, 1978	\$ 5,000.00
Greek Ceramic	Apulian red-figure volute Crater; (c. 360-330 BC); 22-3/8" (56.8 cm) height at rim; duck head handles; masks on both sides	SPB, New York; December 14, 1978	\$ 6,400.00
Greek Ceramic	Hellenistic terra cotta head of a woman; 4th-3rd Century BC; 9¼" (23.5 cm); southern Italy	SPB, New York; December 14, 1978	\$ 5,500.00

PIECE	DESCRIPTION	SELLER	SELLING PRICE
Greek Sculpture	Large Hellenistic terra cotta figure of a woman; 2nd Century BC; 10 $\frac{1}{4}$ " (26 cm)	SPB, New York; December 14, 1978	\$ 200.00
Roman Sculpture	Marble torso of a man; Roman copy of Greek original; 28.3" (72 cm)	Mes. Laurin, Guilloux Buffetaud, Tailleur, Paris; April 26, 1978	\$10,775.00 F 55,000
Roman Sculpture	Marble torso; c. 2nd Century BC; 2'-4 $\frac{1}{2}$ " height (11.2 cm); the female body without head, legs and arms	Sotheby's, London; April 10, 1978	\$ 8,444.25 £ 4,500
Roman Sculpture	Marble Provincial head of a young man; 3rd-4th Century; marble of black plastic socle; 9 $\frac{1}{2}$ " height (24.2 cm)	Christie's, London; April 24, 1978	\$ 2,820.00 £ 1,500
Roman Sculpture	Marble figure of Silvanus, Protector of Fields and Gardens; 2nd-3rd Century AD; 21 $\frac{1}{4}$ " (53.9 cm); standing and wearing a tunic; fruits in his left hand	SPB, New York; December 14, 1978	\$ 3,500.00
Roman Sculpture	Fragmentary marble head of a city goddess; 1st-2nd Century AD; 18" (45.7 cm); deeply carved hair surmounted by crown	SPB, New York; December 14, 1978	\$ 1,000.00
Roman Sculpture	Bronze portrait head of a woman; early 2nd Century AD; Trojan or Hadrian; 13" (33 cm); perhaps likeness of niece of Trajan, Matidia; austere visage; hair bound up; reportedly found during excavations carried out on the 2nd of May, 1879 in the gardens of a house formerly owned by the Salis Soglio counts in Chiavenna	SPB, New York; December 14, 1978	\$90,000.00
Roman Glass	Two pale-green beakers; 1st-2nd Century AD; 2 $\frac{1}{2}$ " & 2-3' $\frac{1}{4}$ " (6.4 cm & 7 cm); both with inward-slating sides	Sotheby's, London; June 20, 1978	\$ 320.00 £ 160
Roman Glass	Violet-red with blue iridescence bottle; 1st half 1st Century; 3.6" (9.2 cm); globular body with rotary-cut lines on the cylindrical neck; ex collection Wheaton College	SPB, New York; December 14, 1978	\$ 900.00
Roman Glass	Blue ovoid bottle with white spiralling thread; 1st Century AD; 4.8" (12.3 cm)	SPB, New York; December 12, 1978	\$ 2,800.00



PIECE	DESCRIPTION	SELLER	SELLING PRICE
Roman Glass	Aubergine-colored flask; 1st-2nd Century AD; 2.5" (6.5 cm); Body formed by head of Janus as a young boy with curly hair	Christie's, London; October 31, 1978	\$ 1,008.20 £ 480
Roman Glass	Iridescent bluish-green beaker; 1st Century AD; 4.9" (12.5 cm); straight flaring sides; decoration motif moulded in four parts probably representing Jupiter, Bacchus, Sylvanus and Neptune; divided by fluted Ionic columns	Sotheby's, London; July 3, 1978	\$24,000.00 £ 13,000
Roman Glass	Translucent green cinerary urn; 2nd Century AD; 11.2" (28.3 cm); with double loop handles; the surface with some iridescence	Christie's, London; November 21, 1978	\$ 7,758.00 £ 4,000
Roman Glass	Aquamarine vase; c. 3rd Century AD; 5½" (14.1 cm); with swirled ridges of lower part of the greenish-yellow body; long neck with flaring rim; coiled collar and handles	SPB, New York; December 14, 1978	\$ 1,500.00
Egyptian Sculpture	Granite head of a man; late New Kingdom 3rd Intermediary Period (1196-712 BC); 22.6" height (8.9 cm); eyebrows and cosmetic lines incised	SPB, New York; May 19, 1979	\$12,500.00
Egyptian Sculpture	Alabaster jar of King Merenptah; Dynasty XIX (1223-1313 BC); 14" height (35.6 cm); the neck engraved with the name and prename of the king flanked by remains of a painted floral collar; the incisions with traces of blue and green pigment; on the shoulder a line of faded ink hieratic inscription.	SPB, New York; May 19, 1979	\$ 7,000.00
Egyptian Sculpture	Granite statue of falcon; pre-Dynastic (c. 3000 BC)	Sotheby's, London;	\$11,035.00 £ 5,000
Egyptian Sculpture	Limestone statuette of a standing man; Dynasty V; 9.7" (24.9 cm)	Brum-Spink-Koller, Zurich; November 8, 1979	\$ 9,428.00 S 15,500
Egyptian Sculpture	Bronze statue of a camel; c. 11-9 Century BC	Albrecht & Hoffman Koln; November 8, 1979	\$ 708.00 DM 1,300
Egyptian Sculpture	Bronze seated figure of a cat; late period; 4-1/8" (10.5 cm)	Sotheby's, London; July 10, 1979	\$ 2,207.00 £ 1,000

PIECE	DESCRIPTION	SELLER	SELLING PRICE
Egyptian Sculpture	Bronze figure of Khonsu; late period; 7" (17.9 cm) standing in a striding position with left leg forward; right arm pendent, left held out before him; pointed beard and long chin	Sotheby's, London; July 10, 1979	\$ 4,414.00 £ 2,000
Egyptian Sculpture	Limestone head of a king; Ptolemaic Period; 7" (17.8 cm)	Sotheby's, London; July 10, 1979	\$ 3,862.25 £ 1,750
Egyptian Sculpture	Large granite seated figure of Rameses II; New Kingdom; 57" (145 cm)	Sotheby's, London; July 10, 1979	\$24,277.00 £ 11,000
Egyptian Sculpture	Pre-Dynasty pottery bowl; (c. 3200 BC); 10½" diameter (26.7 cm); of deep rounded form decorated in brown slip with graduated concentric circles; large pierced handles and flattened rim; rim damaged	Sotheby's, London; July 10, 1979	\$ 3,531.20 £ 1,600
Egyptian Glass	Lower part of an opaque black Kohl glass tube; Tell-el-Amarna Period; 18th Dynasty; 2-3/8" height (6 cm)	Sotheby's, London; April 4, 1979	\$ 4,800.00 £ 2,100
Greek Sculpture	Bronze figure of a horse; (c. 520 BC); 3.8" (9.8 cm); standing on a rectangular base raised on a cylindrical socket	Christie's, Geneva; May 5, 1979	\$13,600.00 S 20,000
Greek Sculpture	Marble head of a woman from a Grave Stele; Attica; 2nd half 4th Century BC; 7.8" height (20 cm); carved in high relief; shown in profile to left; stone stand	Christie's, Geneva; May 5, 1979	\$53,100.00 S 90,000
Greek Sculpture	Terra cotta statuette; Polos, Chiton & Himation; clad figures; 5th Century BC; 6.2" (15.9 cm)	Sotheby's, London; July 10, 1979	\$ 706.00 £ 320
Greek Sculpture	Marble statue of man and barber; Boeotian; (c. 460 BC); 5.5" x 5.3" (14 x 13.5 cm)	Spink-Koller, Zurich; October 18, 1979	\$27,981.00 S 46,000
Greek Sculpture	Marble statue of Eros; 3rd Century BC; Boeotian; 2.5" (6.5 cm); ex Brummer collection	Spink-Koller, Zurich; October 18, 1979	\$ 3,224.00 S 5,300

PIECE	DESCRIPTION	SELLER	SELLING PRICE
Greek Sculpture	Marble statue of a young woman; Myrina; 2nd Century BC	Sotheby's, London; July 10, 1979	\$19,980.00 £ 9,000
Greek Sculpture	Marble statue of Aphrodite; Myrina; 3rd Century BC	Sotheby's, London; July 10, 1979	\$ 9,270 £ 4,200
Greek Ceramic	Black figure Hydria; Attica; last quarter 6th Century BC; 19.2" height (49 cm); decorated in panels with the Judgment of Paris on the shoulder with warriors in combat; the predella with a siren between two panthers	Christie's, London; May 31, 1979	\$16,425.00 £ 8,000
Greek Ceramic	Hydria, Attic; (c. 520 BC); by the Leagros Painter; 23.2" height (59 cm); black figured, the front with a reserved panel depicting Herakles, Athena, Dionysus, Artemis, at a quadriga; the shoulder with a battle scene; the base of the handle with a reserved panel containing an inverted palmette; incised; with white and purple painted details; the base incised with a two-letter graffito	Christie's, Geneva; May 5, 1979	\$23,800.00 S 35,000
Greek Ceramic	Red figure Kylix; Attic; (c. 550 BC); 9" rim diameter (23 cm); low stemmed, the exterior with Dionysys between two satyrs holding an kantheros and a vine branch; interior with a medallion of a seated youth within meander surround; repaired in antiquity	Christie's, Geneva; May 5, 1979	\$27,200.00 S 40,000
Greek Ceramic	Red figure column Krater Attica; 480-470 BC; by the Flying Angel Painter; 15.5" (39.5 cm); with Dionysus on a donkey and a satyr with interlaced lotus buds in black in the rim; palmettes above each handle; rays radiating from the base	Christie's, London; May 31, 1979	\$18,480.00 £ 9,000
Greek Ceramic	Kalpis; 500-480 BC; by Eucharides; 16 1/1" (41 cm) height; red-figured; the shoulder panel with Hermes slaying the multi-eyed Argos Panoplos; base incised with a graffito mark and painted with the letter K; repaired and restored	Christie's, Geneva; May 5, 1979	\$129,200.00 S 190,000
Greek Ceramic	Vase; (c. 570 BC)	Sotheby's, London; December 12, 1979	\$25,200.00 £ 11,200

PIECE	DESCRIPTION	SELLER	SELLING PRICE
Greek Ceramic	Kylix; (c. 550 BC); 10.8" (27.5 cm); depicting Nike	SPB, New York; December 13, 1979	\$ 2,200
Greek Glass	Flask; 4th Century BC; 15.7" (39.9 cm); cylindrical form	Sotheby's, London; December 4, 1979	\$ 885.00 £ 400
Roman Sculpture	Bronze figure of Aphrodite; 1st Century BC-1st Century AD; 9.1" (23.3 cm); the slender goddess standing; her left hand held before her	SPB, New York; May 19, 1979	\$18,000.00
Roman Sculpture	Bronze bust of a lady; (c. 20-30 AD); 11.9" (30.2 cm); probably Antonia, the mother of Claudius of the Empress Livia, wife of Augustus	SPB, New York; May 19, 1979	\$24,000.00
Roman Sculpture	Bronze figure of Oikumene; second half 2nd Century; 22" height (55.8 cm); holding ear of grain in right hand	SPB, New York; May 19, 1979	\$46,000.00
Roman Sculpture	Limestone figure of a woman; 1st Century BC; 48" height (122 cm)	SPB, New York; December 13, 1979	\$ 5,500.00
Roman Sculpture	Marble portrait of a man; 14.5" height (37 cm)	Spink-Koller, Zurich; October 18, 1979	\$ 5,475.00 S 9,000
Roman Sculpture	Marble statue of Poseidon; 1st Century BC (no dimensions available)	Christie's, London; November 28, 1979	\$ 4,400.00 £ 2,000
Roman Sculpture	Marble head of Dionysus; second half 1st Century BC (no dimensions available)	Spink-Koller, Zurich; October 18, 1979	\$48,665.00 S 80,000
Roman Sculpture	Marble bust of Titus; 1st Century BC; 17.7" height (45 cm)	Christie's, London; November 28, 1979	\$ 4,400.00 £ 2,000
Roman Ceramic	Pottery flask; late 1st Century AD; 7½" (19.1 cm)	Sotheby's, London; July 10, 1979	\$ 550.00 £ 250
Roman Glass	Amber cast glass bowl; 1st Century AD; 7.8" diameter (20 cm); ex collection Constable-Maxwell	Sotheby's, London; July 4, 1979	\$10,388.50 £ 5,000

PIECE	DESCRIPTION	SELLER	SELLING PRICE
Roman Glass	Flask; 2nd Century AD; 5" (13 cm)	Christie's, Geneva; May 5, 1979	\$ 10,880.00 S 1,600
Roman Glass	Glass-cage cup; late Roman Period (c. 300 AD); 3.9" height (10 cm); colorless glass with white, flaking iridescence on inner and outer surfaces; slightly damaged; ex collection Constable-Maxwell; <u>note</u> : this bowl is the only surviving example of its type	Sotheby's, London; July 4, 1979	\$1,081,600.00 £ 520,000
Roman Glass	Opaque red glass flask; 6½" height (16.5 cm); 1st Century BC-1st Century AD; grooved ribs, round base, shoulder and rim	Sotheby's, London; July 4, 1979	\$ 20,500.00 £ 9,000
Roman Glass	Large amber cast pillar-molded bowl; 4-5/8" (11.7 cm); with prominent diagonal and vertical ribs	Sotheby's, London; July 4, 1979	\$ 11,400.00 £ 5,000
Roman Glass	Translucent brilliant blue and white "marbled" pyxis and cover; 1st Century AD; 3½" overall (8.9 cm)	Sotheby's, London; July 4, 1979	£ 7,000
Roman Glass	Large pale green mould-blown glass head flask; 6½" height (16.5 cm); 2nd-3rd Century AD	Sotheby's, London; July 4, 1979	\$ 24,000 £ 10,500
Roman Glass	Yellowish-green glass cup; 1st Century AD; 2-3/8" height (6 cm)	Sotheby's, London; July 4, 1979	\$171,000.00 £ 75,000
Egyptian Sculpture	Granite statue of Amun; XIII Dynasty (1785-1650 BC); 15.9" height (40.6 cm)	SPB, New York; May 16, 1980	\$ 32,000.00
Egyptian Sculpture	Relief fragment; Tel-el-Amarna; XVIII Dynasty (c. 1375-1730 BC); 7.9" x 13.7" (20.3 cm x 34.9 cm)	SPB, New York; Ma 16, 1980	\$ 14,000.00
Egyptian Sculpture	Steatite Pharaoh's head; XXII Dynasty (946-720 BC); 2.2" (5.6 cm)	SPB, New York; May 16, 1980	\$ 6,500.00
Egyptian Sculpture	Bronze sculpture of a falcon; XXX Dynasty; 8.2" (21 cm)	Christie's, London; April 23, 1980	\$ 18,000.00 £ 8,000

PIECE	DESCRIPTION	SELLER	SELLING PRICE
Egyptian Sculpture	Sandstone head of Rameses II; XIX Dynasty; 25" (63.5 cm)	SPB, New York; December 11, 1980	\$ 15,000.00
Egyptian Sculpture	Mummy of the House of Taawa (female); Thebes; XXV-XXVI Dynasty; 68" x 20" (175 x 51 cm)	Sotheby's, London; July 15, 1980	\$ 40,430.00 £ 17,000
Egyptian Sculpture	Marble statue of Isis; XXVI Dynasty; Ptolemaic Period (664-200 BC); 15" height (38.1 cm)	SPB, New York; December 11, 1980	\$ 8,000.00
Egyptian Sculpture	Statue of a bronze cat; 4th-3rd Century BC; 14½" (36 cm)	Christie's, London; December 26, 1980	\$151,380.00 £ 45,000
Greek Sculpture	Marble statue of figures in Chiton and Himation; 2nd Century BC; 4.9" (12.5 cm)	Munzen und Medaillen AG Basel; February 19, 1980	\$ 2,335.00 S 3,800
Greek Sculpture	Statuette of young Herakles; 1st Century BC; 9.5" height (24 cm)	Munzen und Medaillen AG Basel; February 19, 1980	\$ 3,812.00 S 6,200
Greek Sculpture	Terra cotta statue of Hermes; 5th Century BC; 8.5" height (19.2 cm)	Sotheby's, London; July 15, 1980	\$ 1,165.00 £ 700
Greek Sculpture	Limestone statue of a figure; 5th Century BC; 20.3" height (51.7 cm)	Sotheby's, London; December 8, 1980	\$ 6,490.00 £ 2,800
Greek Sculpture	Votive Stele; Attica; (c. 380 BC); marble; 15.1" x 18" (37.5 x 45.7 cm)	Sotheby's, London; July 15, 1980	\$ 9,035.00 £ 3,800
Greek Sculpture	Marble grave Stele; Attica; 4th Century BC; 27.9" x 18.8" (71 x 48 cm)	SPB, New York; December 11, 1980	\$ 20,000.00
Greek Ceramic	Xylix; by the Master of Boston; Attica; (560-550 BC); 5" height (14 cm); 10.9" diameter (27.8 cm)	Munzen und Medaillen Basel; February 2, 1980	\$ 17,215.00 S 28,000

PIECE	DESCRIPTION	SELLER	SELLING PRICE
Greek Ceramic	Amphora; Attica; (c. 530 BC); 17.7" (45 cm) height	Munzen und Medaillen, Basel; February 19, 1980	\$ 9,222.00 \$ 15,000
Greek Ceramic	Krater; Attica; (c. 530 BC); in the style of the the Lysippus Master; 11.6" height (29 cm); 14" diameter	Munzen und Medaillen, Basel; February 19, 1980	\$ 8,915.00 \$ 14,500
Greek Ceramic	Amphora; c. 520-510 BC; 16.2" (41.3 cm); depicting Herakles with the centaur Pholos	SPB, New York; May 16, 1980	\$ 15,000.00
Greek Ceramic	Amphora; Attica; (c. 520-510 BC); 11.6" height (29.5 cm)	Munzen und Medaillen, Basel; February 19, 1980	\$ 41,806.00 \$ 68,000
Roman Sculpture	Marble head of a Roman official; 10" height (25.5 cm); second half 1st Century AD	Munzen und Medaillen, Basel;	\$ 10,452.00
Roman Sculpture	Marble Aphrodite from 4th Century; prototype; 1st Century AD; 46-3/4" height	SPB, New York; May 2, 1980	\$ 6,500.00
Roman Sculpture	Marble goddess figure; (c. 2nd Century AD); 29 1/4" height; seated; head missing		\$ 700.00
Roman Sculpture	Woman's head in marble; first half 1st Century AD; 5 1/2" height; centrally parted hair	SPB, New York; July 5, 1980	\$ 650.00
Roman Sculpture	Bronze Aphrodite looking at mirror; first half 1st Century AD; 10-1/8" height; nude; looking at mirror in hand	SPB, New York May 2, 1980	\$ 3,200.00
Roman Sculpture	Bronze Aphrodite; 1st Century AD; 5-3/4" height; slender figure; high circular base	SPB, New York; July 5, 1980	\$ 18,000.00
Roman Sculpture	Bronze goddess; (c. 1st Century AD); 4-5/8" height; clad in finely pleated chiton	SPB, New York; July 5, 1980	\$ 5,000.00

PIECE	DESCRIPTION	SELLER	SELLING PRICE
Roman Sculpture	Bronze bust of a lady; 20-30 AD; 4-3/4" with pedestal; possibly Antonia	SPB, New York; July 5, 1980	\$ 24,000.00
Roman Sculpture	Bronze hollow cast sculpture of Tyche; first half 1st Century, first third 1st Century; standing wearing diadem	SPB, New York; July 5, 1980	\$ 1,800.00
Roman Glass	Bottle; amber; ribbed melon shaped body; 2nd Century AD; 2 1/2"	SPB, New York; July 5, 1980	\$ 200.00
Roman Glass	Bottle; brown; pyriform body, narrow neck threads; missing foot; first 3/4 of the 1st Century; 3-3/4"	SPB, New York; November 10, 1980	\$ 100.00
Roman Glass	Bottle; greenish-blue; round body, flaring neck; first 3/4 of 1st Century; 4-5/8"	SPB, New York; November 10, 1980	\$ 200.00
Roman Glass	Bowl; yellowish green; spiral ribbing; splayed foot; first 3/4 of 1st Century; 8-5/8" height	SPB, New York; November 10, 1980	\$ 550.00
Roman Glass	Flask; greenish; handle-less amphorisk; flaring mouth; 2nd-3rd Century AD; 6 1/2" height	SPB, New York; November 10, 1980	\$ 800.00
Roman Glass	Jar; amber; globular body; pinched vertical ribs; first 3/4 of 1st Century; 3-5/8" height	SPB, New York; November 10, 1980	\$ 275.00
Roman Glass	Jug; greenish; cylindrical neck; flaring rim; 2nd Century AD; 3 1/4" height	SPB, New York; November 10, 1980	\$ 225.00
Roman Glass	Pitcher; aubergine; globular body; coiled collar rim; first 3/4 of 1st Century; 4-5/8" height	SPB, New York; November 10, 1980	\$ 325.00
Roman Glass	Unguentarium; bluish-green; heavy, conical body; flat base; 2nd-3rd Century AD; 4-3/4"	SPB, New York; November 10, 1980	\$ 300.00
Roman Glass	Vase; greenish, broad shallow fluting, iridescent; first 3/4 1st Century; 7-5/8" height	SPB, New York; November 10, 1980	\$ 950.00



PIECE	DESCRIPTION	SELLER	SELLING PRICE
Egyptian Sculpture	Bronze figure of Amun, early Dynasty XXVI; 9" (22.8 cm); striding god weawring a kilt and tall headdress; corroded	Christie's, London; July 8, 1981	\$ 350.00 £ 180
Egyptian Sculpture	Bronze head of cat; 1½" (4 cm); 6th-4th Century BC	Christie's, London; July 8, 1981	\$ 425.00 £ 220
Egyptian Sculpture	Bronze seated figure of Isis suckling Harpocrates; 4th-2nd Century BC; 3-¾" (9.6 cm)	Christie's, London; July 8, 1981	\$ 540.00 £ 280
Egyptian Sculpture	Bronze figure of a goddess; Ptolemaic; 7¼" (18.4 cm)	Christie's, London; July 8, 1981	\$ 926.00 £ 480
Egyptian Sculpture	Bronze seated figure of Isis and Harpocrates; 9-¾" (25 cm); early Dynasty XXVI	Christie's, London; July 8, 1981	\$ 1,737.00 £ 900
Egyptian Sculpture	Bronze figure of Horus the Falcon; late Period; 6½" length (16.5 cm)	Christie's, London; July 8, 1981	\$ 1,350.00 £ 700
Egyptian Sculpture	Bronze head of a cat; XXVI Dynasty; 2" height	Christie's, New York; April 15, 1981	\$ 800
Egyptian Sculpture	Bronze seated Osiris; 6½" height	Christie's, New York; April 15, 1981	\$ 130.00
Egyptian Sculpture	Bronze figure of Harpocrates; XXVI Dynasty; 3¼" (8.2 cm)	Sotheby's, London; July 27, 1981	\$ 385.00 £ 200
Egyptian Sculpture	Bronze figure of Isis and Harpocrates; Ptolemaic; 3rd-1st Century BC; 3-¾" (9.5 cm)	Christie's, London; December 10, 1981	\$ 490.00 £ 275
Egyptian Sculpture	Bronze statuette of Nefertum; Late Period; 6½" (16.5 cm)	Christie's, London; December 12, 1981	\$ 465.00 £ 242
Egyptian Sculpture	Bronze figure of Osiris; 6th-4th Century BC; 5" (12.8 cm)	Christie's, London; December 12, 1981	\$ 633.00 £ 330

PIECE	DESCRIPTION	SELLER	SELLING PRICE
Egyptian Sculpture	Bronze statue of Sekhmet; Late Period; 7-3/8" (18.8 cm)	Christie's, London; December 10, 1981	\$ 672.00 £ 350
Egyptian Sculpture	Basalt statue of standing official; Late Period; 13-7/8" (35.4 cm)	Christie's, London; December 10, 1981	\$ 4,800.00 £ 2,500
Egyptian Sculpture	Greenish-grey schist head of an official; Dynasty XXVII; Early 5th Century BC; 4 1/2" (10.7 cm)	Christie's, London; December 10, 1981	\$ 24,288.00 £ 12,650
Egyptian Sculpture	Hollow cast bronze figure of a seated cat (dimensions unavailable)	Christie's, London; December 10, 1981	\$ 31,680.00 £ 16,500
Egyptian Sculpture	Bronze figure of Osiris; XXVI Dynasty; 9 1/4" (23.5 cm)	SPB, New York; December 9, 1981	\$ 1,980.00
Egyptian Sculpture	Bronze figure of Isis with Horus; Late Period; 11-3/4" (29.9 cm)	SPB, New York; December 9, 1981	\$ 3,300.00
Egyptian Sculpture	Bronze figure of Harpoerates; 22nd-26th Dynasty; 4" (10.1 cm)	SPB, New York; December 9, 1981	\$ 1,320.00
Egyptian Sculpture	Bronze figure of Baster; 26th-30th Dynasty; 5" (12.6 cm)	SPB, New York; December 9, 1981	\$ 2,500.00
Egyptian Sculpture	Granite head of a man; 13th Dynasty; 3 1/4" (8.3 cm)	SPB, New York; December 9, 1981	\$ 5,500.00
Egyptian Ceramic	Faience figures; all sales - average @		\$ 200-450
Greek Sculpture	Greek terra cotta figure	Christie's, New York; April 15, 1981	\$ 250.00
Greek Sculpture	Marble head of Pallas Athena; 3rd Century BC; 5-3/4" (14.5 cm)	Christie's, London; July 8, 1981	\$ 2,110.00 £ 720

PIECE	DESCRIPTION	SELLER	SELLING PRICE
Greek Sculpture	Marble head of Dionysus; 3rd-4th Century BC; 8¼" (21 cm)	Christie's, London; December 10, 1981	\$ 2,000.00 £ 572
Greek Sculpture	Hellenistic marble head of a goddess; late 4th-early 3rd Century BC; 11½" (29.2 cm)	SPB, New York; September 12, 1981	\$ 33,000.00
Greek Glass	Core-fashioned translucent blue vase; (c. 3rd Century BC); 2½" (6.4 cm)	Christie's, London; December 10, 1981	\$ 670.00 £ 350
Greek Ceramic	Attic red figure Pelike; 5th Century BC; 13" (33 cm)	Christie's, London; July 8, 1981	\$ 2,000.00 £ 1,500
Greek Ceramic	Apulian red figure Pelike; late 4th Century BC; 15½" (39.3 cm)	Christie's, London; July 8, 1981	\$ 2,125.00 £ 1,100
Greek Ceramic	Attic black figure eye cup; 6th Century BC; 3¼" (8.3 cm)	Christie's, London; July 8, 1981	\$ 425.00 £ 220
Greek Ceramic	Attic black figure shallow plate; 6th Century BC; 8¼" (21 cm)	Christie's, London; July 8, 1981	\$ 1,060.00 £ 550
Greek Ceramic	Attic black figure Siana cup; manner of C Painter; second quarter of 6th Century BC; 11" diameter (17.8 cm)	SPB, New York; December 9, 1981	\$ 5,000.00
Greek Ceramic	Attic black figure panel Amphora; (c. 540-530 BC); 11¼" height (28.2 cm)	SPB, New York; December 9, 1981	\$ 1,870.00
Greek Ceramic	Attic black figure Lekythos from the Class of Athens; and bodied lekythos; 5th Century BC; 7¼" (18.2 cm) and 9½" (24.1 cm)	Christie's, London; December 10, 1981	\$ 1,796.00 £ 935
Greek Ceramic	Attic white ground pattern Lekythos from the Beldam Workshop; 5th Century BC; 8" (20.2 cm)	Christie's, London; December 10, 1981	\$ 1,536.00 £ 800
Greek Ceramic	Attic black figure Siana cup near the Griffin Painter; second quarter 6th Century; 13½" (34.4 cm)	Christie's, London; December 10, 1981	\$ 3,500.00 £ 1,800

PIECE	DESCRIPTION	SELLER	SELLING PRICE
Greek Ceramic	Attic black figure Kylix; late 6th Century; 14-3/4" (37.2 cm)	Christie's, London; December 10, 1981	\$ 2,880.00 £ 1,500
Greek Ceramic	Attic black figure neck Amphora; near the Antimenes Painter; (c. 520 BC); 16-1/8" (41 cm); condition: intact; provenance Etruscan tomb; Wurzburg Museum	Christie's, London; December 10, 1981	\$ 29,570.00 £ 15,400
Greek Ceramic	Attic black figure neck Amphora; from the Group of Berkeley 8.3376; (c. 520 BC); 16 1/2" (42 cm); condition: intact	Christie's, London; December 10, 1981	\$ 31,680.00 £ 16,500
Roman Sculpture	Marble head of a snarling leopard; 2nd Century AD; 3 1/4" (8.2 cm); listed in Antiquities Journal	Christie's, London; July 8, 1981	\$ 330.00 £ 170
Roman Sculpture	Marble head of Herakles; 3rd Century AD; 5 1/4" (13.4 cm)	Sotheby's, London; July 27, 1982	\$ 185.00 £ 95
Roman Sculpture	Terra cotta figure of Aphrodite; half Century AD; 8 1/2" (21.6 cm)	Sotheby's, London; July 27, 1981	\$ 960.00 £ 460
Roman Sculpture	Marble male head; 2nd Century AD; 5 1/4" (13.3 cm)	Sotheby's, London; July 27, 1981	\$ 620.00 £ 300
Roman Sculpture	Marble figure of a young god or athlete; (c. early 2nd Century AD); 27 1/2" (69.9 cm); references	SPB, New York; December 9, 1981	\$ 17,600.00
Roman Sculpture	Marble torso of Artemis; (c. 1st Century AD); 31" (78.7 cm)	SPB, New York; December 9, 1981	\$ 18,700.00
Roman Sculpture	Marble torso of Sylvanus; (c. 2nd half of 2nd Century); 24 1/2" (62.2 cm); provenance: Brummer; Koller & Spink, 1979	SPB, New York; December 9, 1981	\$ 27,500.00
Roman Sculpture	Marble head of Dionysus; 2nd Century AD; 4-1/8" (10.5 cm)	SPB, New York; December 9, 1981	\$ 5,500.00
Roman Sculpture	Marble head of Apollo; 1st Century AD; 13-3/4" (34.9 cm)	SPB, New York; December 9, 1981	\$ 7,150.00

PIECE	DESCRIPTION	SELLER	SELLING PRICE
Roman Sculpture	Marble figure of a hunter with his dog; (c. 220-240 AD); 18 $\frac{1}{4}$ " (46.5 cm)	SPB, New York; December 9, 1981	\$ 15-20,000 est.; didn't sell
Roman Sculpture	Marble head of sleeping Eros; (c. 1st Century AD); 11" (27.9 cm)	SPB, New York; December 9, 1981	\$ 4,620.00
Roman Sculpture	Marble portrait head of a man; (c. second half of 1st Century BC); 14 $\frac{1}{2}$ " (36.8 cm)	SPB, New York; December 9, 1981	\$ 13,200.00
Roman Sculpture	Marble head of Emperor Commodus; (c. 185-211 AD); 14 $\frac{1}{4}$ " (36.2 cm)	SPB, New York; December 9, 1981	\$ 38,700.00
Roman Ceramic	Grey pottery jar; (c. 3rd-4th Century AD); 6 $\frac{1}{2}$ " (16.5 cm)	Sotheby's, London; July 27, 1982	\$ 60.00 £ 30
Roman Glass	Light amber ribbed glass bowl; 1st-2nd Century AD; 5"	Christie's, New York; April 15, 1981	\$ 460.00
Roman Glass	Light green glass bottle; 2nd-3rd Century AD; 9 $\frac{1}{4}$ "	Christie's, New York; April 15, 1981	\$ 825.00
Roman Glass	Light green bottle; 2nd-3rd Century AD; 6-3/4"	Christie's, New York; April 15, 1981	\$ 280.00
Roman Glass	Green glass Amphoriskos; applied twin handles; high iridescence; 4th-5th Century AD; 8 $\frac{1}{2}$ " (21.5 cm)	Christie's, London; July 8, 1981	\$ 1,390.00 £ 720
Roman Glass	Blue translucent flask; spiral threads; 1st Century AD; 3-3/4" (9.5 cm)	Christie's, London; July 8, 1981	\$ 640.00 £ 330
Roman Glass	Translucent green glass Janus-headed flask; 3rd Century AD; 3 $\frac{1}{4}$ " (8.3 cm)	Christie's, London; July 8, 1981	\$ 470.00 £ 240
Roman Glass	Green flask; 4th Century AD; 4 $\frac{1}{2}$ " (11.5 cm)	Christie's, London; July 8, 1981	\$ 1,275.00 £ 660

PIECE	DESCRIPTION	SELLER	SELLING PRICE
Roman Glass	Olive green glass flask; 4th Century AD; 4-1/8" (4.5 cm)	Sotheby's, London; July 27, 1981	\$ 190.00 £ 99
Roman Glass	Olive green jug; 2nd Century AD; 6-7/8" (17.5 cm)	Sotheby's, London; July 27, 1981	\$ 461.00 £ 240
Roman Glass	Colorless double-bodied Unguentarium; 2nd Century AD; 3 1/4" (9.5 cm)	Sotheby's, London; July 27, 1981	\$ 325.00 £ 170
Roman Glass	Pale bluish-green bottle; 3rd Century AD; 9-1/8" (23.2 cm)	Sotheby's, London; July 27, 1981	\$ 465.00 £ 240
Roman Glass	Aquamarine ribbed bowl; 1st Century AD; 4-15/16" (12.5 cm)	Sotheby's, New York; December 9, 1981	\$ 600.00
Roman Glass	Pale aubergine twin-handled bottle; 2nd Century AD; 3-1/8" (7.9 cm)	Sotheby's, New York; December 9, 1981	\$ 495.00
Roman Glass	Marbled blue bottle; 1st-2nd Century AD; 4 1/2" (11.4 cm)	Sotheby's, New York; December 9, 1981	\$ 660.00
Roman Glass	Cobalt blue, mold-brown bottle, Sidon; 1st-2nd Century AD; 3-3/4" (9.6 cm)	Sotheby's, New York; December 9, 1981	\$ 605.00
Roman Glass	Bluish jar with five handles; 3rd-5th Century AD; 3-1/16" (7.8 cm)	Sotheby's, New York; December 9, 1981	\$ 1,320.00
Roman Glass	Translucent green glass flask with swirling fluted body; (c. 3rd Century AD); 11 1/2" (8.2 cm)	Christie's, London; December 10, 1981	\$ 890.00 £ 462
Roman Glass	Green glass Amphora; 3rd Century AD; 11 1/2" (29.2 cm)	Christie's, London; December 10, 1981	\$ 1,584.00 £ 825
Roman Glass	Translucent pale green glass bowl; (c. 1st Century AD); 2 1/4" (5.6 cm) high; 3-3/4" (9.5 cm) diameter;	Christie's, London; December 10, 1981	\$ 1,056.00 £ 550

PIECE	DESCRIPTION	SELLER	SELLING PRICE
Egyptian Sculpture	Bronze figure of a divinity; 25th Dynasty (745-664 BC); 6" (15.2 cm)	SPB, New York; February 24, 1982	\$ 770.00
Egyptian Sculpture	Bronze figure of Isis; 26th-30th Dynasty (664-342 BC); 4-3/8" (11.1 cm)	SPB, New York; February 24, 1982	\$ 400.00
Egyptian Sculpture	Bronze figure of Harpocrates; Later Period (712-30 BC); 4-7/8" (12.4 cm)	SPB, New York; February 24, 1982	\$ 440.00
Egyptian Ceramic	Faience figures	SPB, New York; February 24, 1982	\$ 450.00
Greek Ceramics	Attic black figure Lekythos; late 6th Century BC; 7-1/8" (18.7 cm)	SPB, New York; February 24, 1982	\$ 1,980.00
Greek Ceramic	Fragmentary Attic black figure column Krater; (c. 500 BC); 13 1/2" height (34.2 cm)	SPB, New York; February 24, 1982	\$ 1,320.00
Greek Ceramic	Apulian Oinochoe; (c. 350-300 BC); 2-3/4" diameter, 4" height	Arrowsmiths, Arizona; March 3, 1982	\$ 225.00
Roman Sculpture	Bronze figure of Hermes; 1st-2nd Century AD; 9-3/4" (24.8 cm)	SPB, New York; February 24, 1982	\$ 935.00
Roman Sculpture	Marble head of Dionysus; 1st-2nd Century AD; 3 1/4" (8.2 cm)	SPB, New York; February 24, 1982	\$ 605.00
Roman Sculpture	Roman marble head of a goddess; 3rd-4th Century AD; 12 1/2" (31.8 cm)	SPB, New York; February 24, 1982	\$ 1,320.00
Roman Glass	Colorless facet-cut beaker; 1st-2nd Century AD; 4.7" height (12 cm)	Hadji Baba, London; January 7, 1982	\$ 15,300.00 £ 8,500
Roman Glass	Bluish-green bottle; (c. 2nd Century AD); 8" (20.3 cm)	SPB, New York; February 24, 1982	\$ 385.00

PIECE	DESCRIPTION	SELLER	SELLING PRICE
Roman Glass	Aquamarine jug; (c. 3rd-5th Century AD); 4-3/4" height (12.2 cm)	SPB, New York; February 24, 1982	\$ 385.00
Roman Glass	Greenish glass bottle; 1st Century AD; 7" (17.8 cm)	SPB, New York; February 24, 1982	\$ 440.00
Roman Glass	Aquamarine ribbed bowl; 1st Century AD; 6-1/8" (15.6 cm)	SPB, New York; February 24, 1982	\$ 440.00
Roman Glass	Greenish sprinkler bottle; 3rd-5th Century AD; 4-5/8" (11.7 cm)	SPB, New York; February 24, 1982	\$ 247.00



APPENDIX II

COMPUTER PRINTOUTS OF GRAPHS



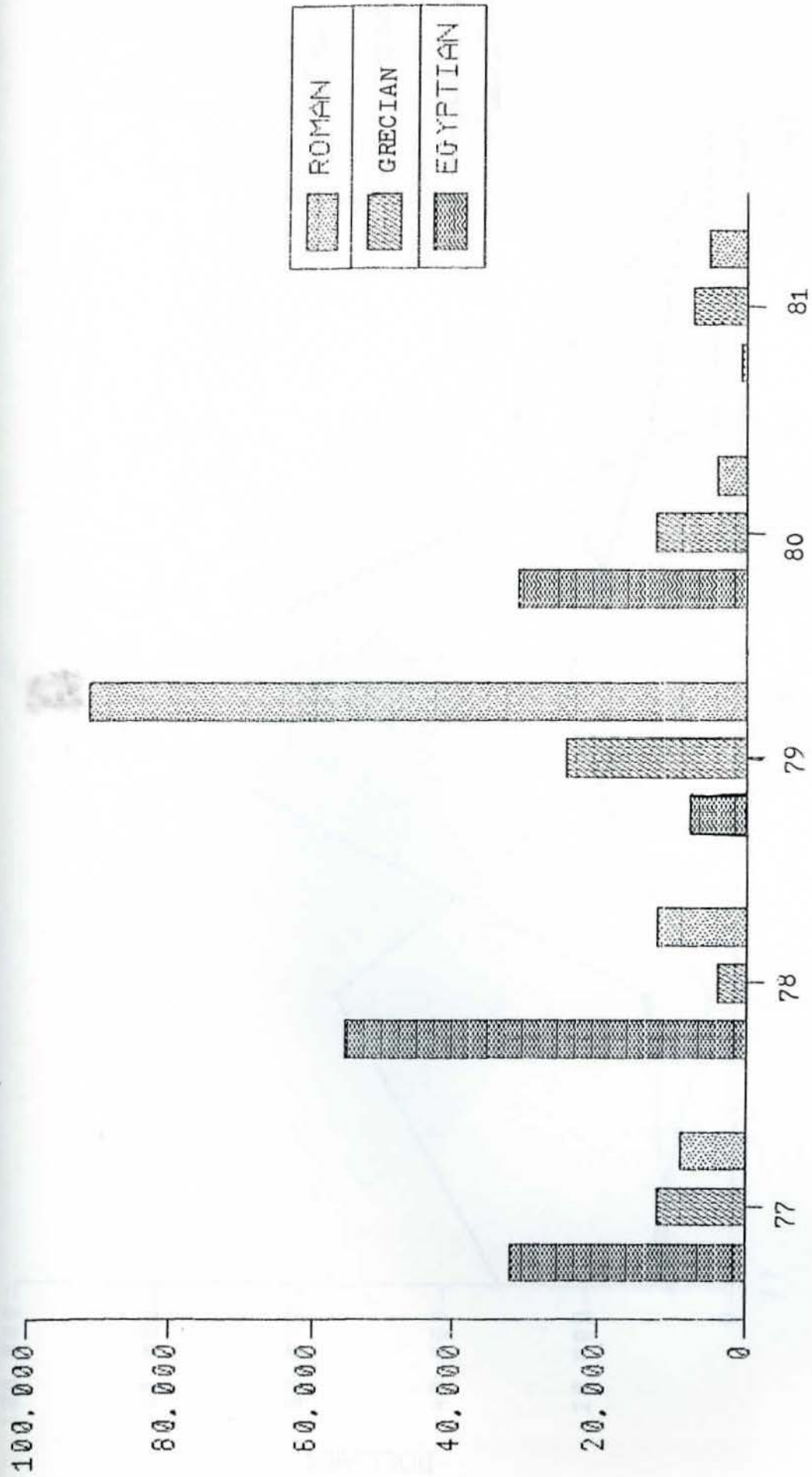

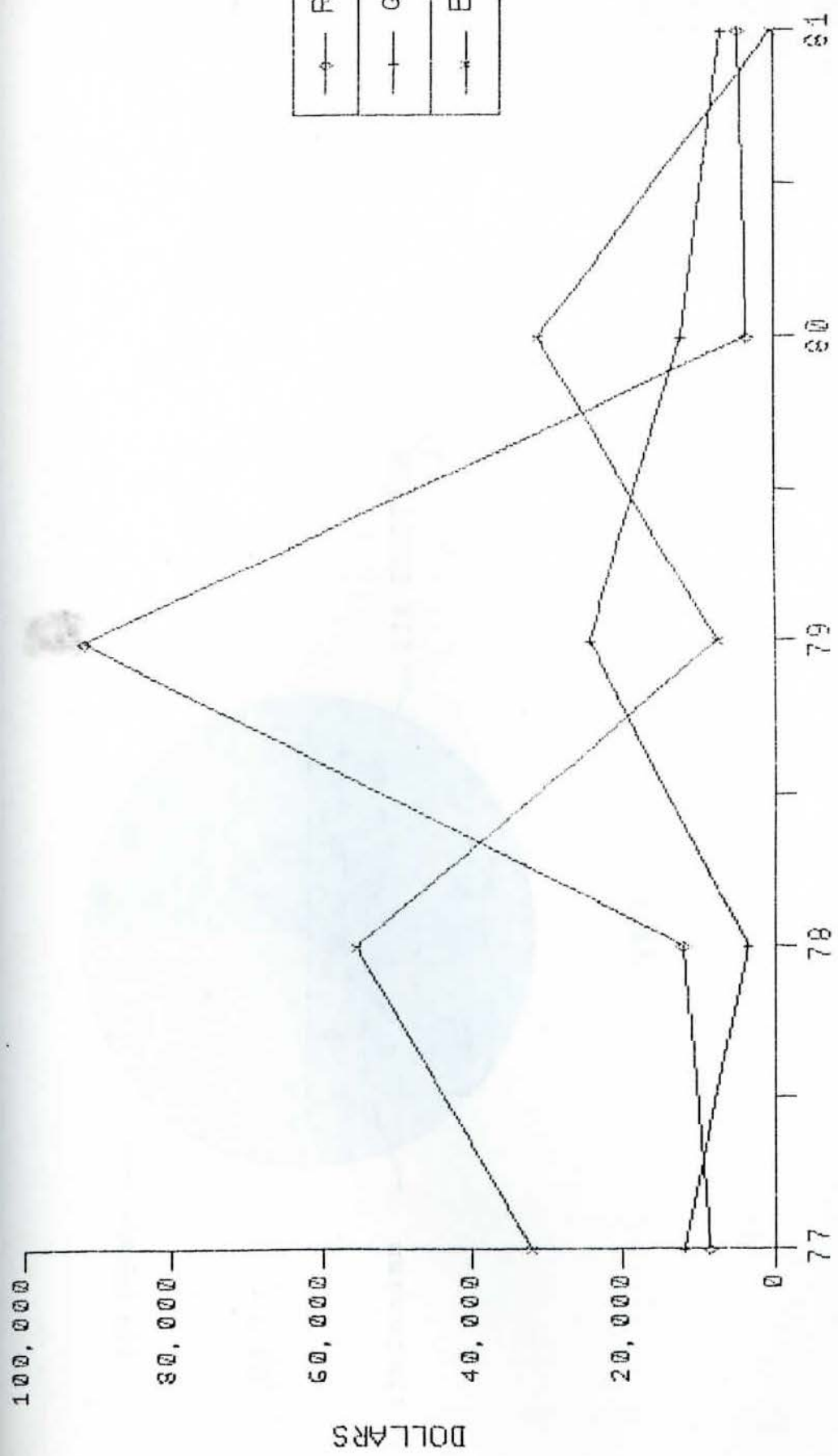

—◆—	ROMAN
-+-	GRECIAN
-x-	EGYPTIAN

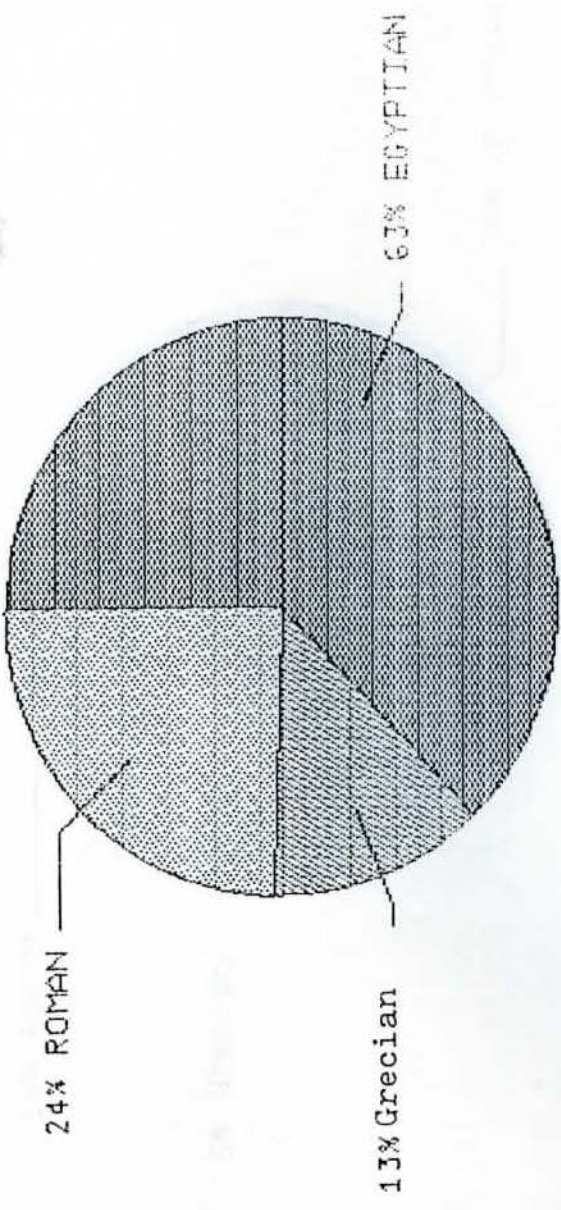

1977

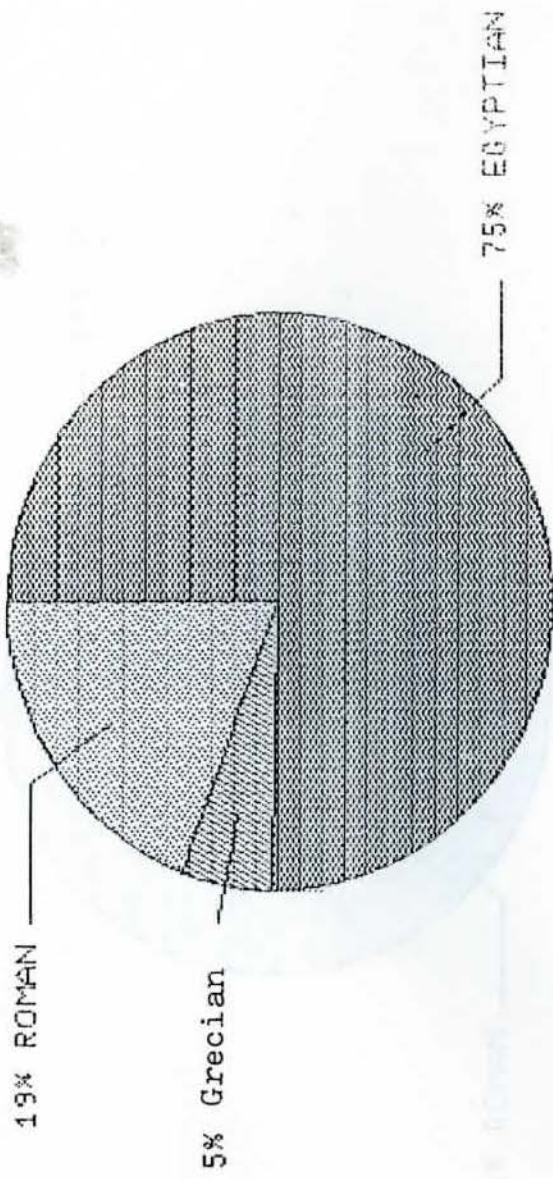

1978

4% EGYPTIAN

19% Grecian

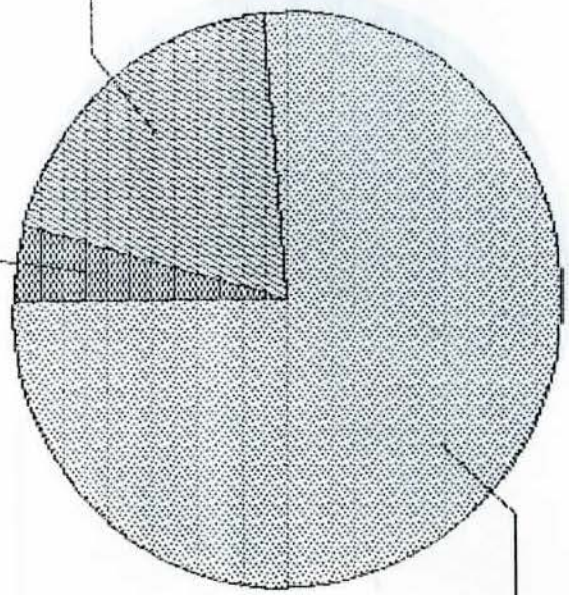

76% ROMAN

1979

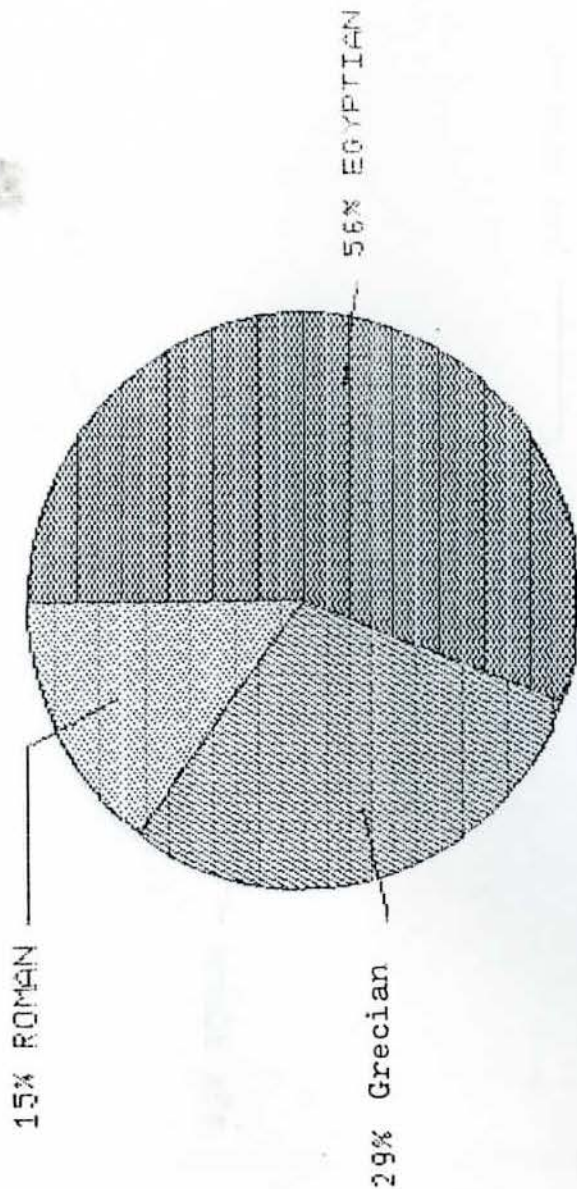

1980

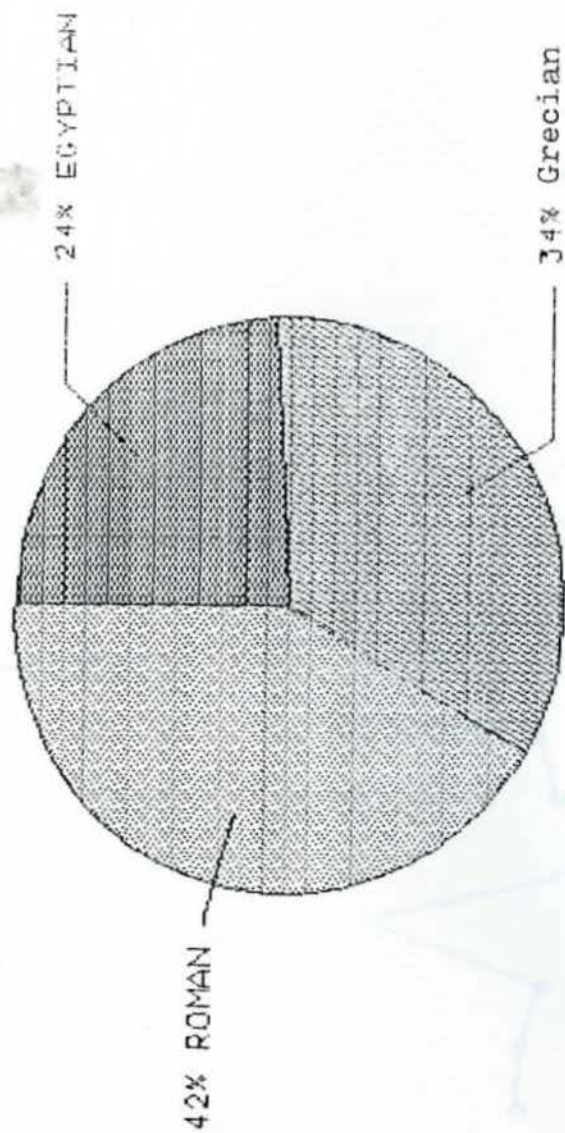

1981



TOTAL DOLLAR SALES BY QUARTER FOR EGYPT

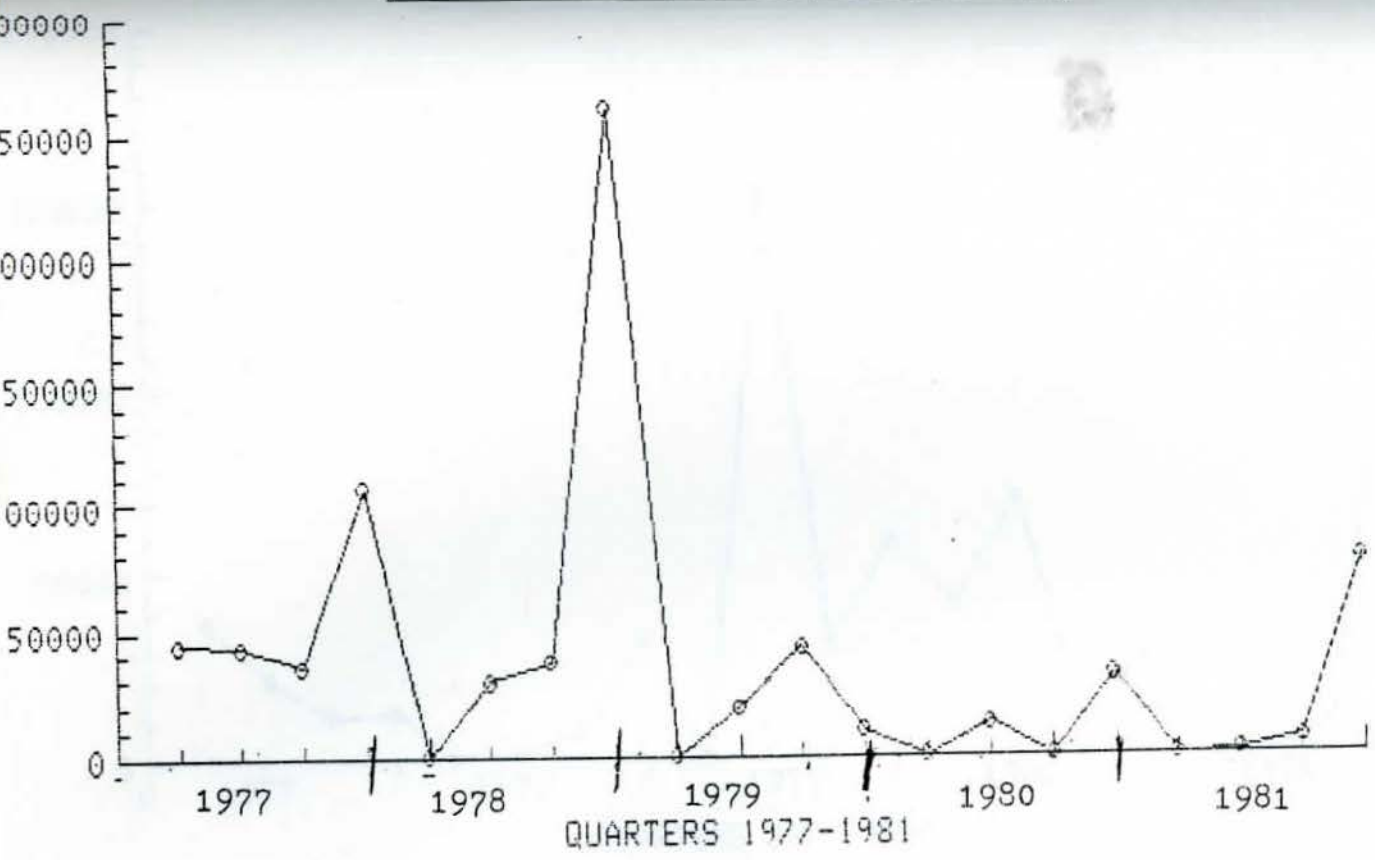

-H-

TOTAL DOLLAR SALES BY QUARTER FOR GREECE

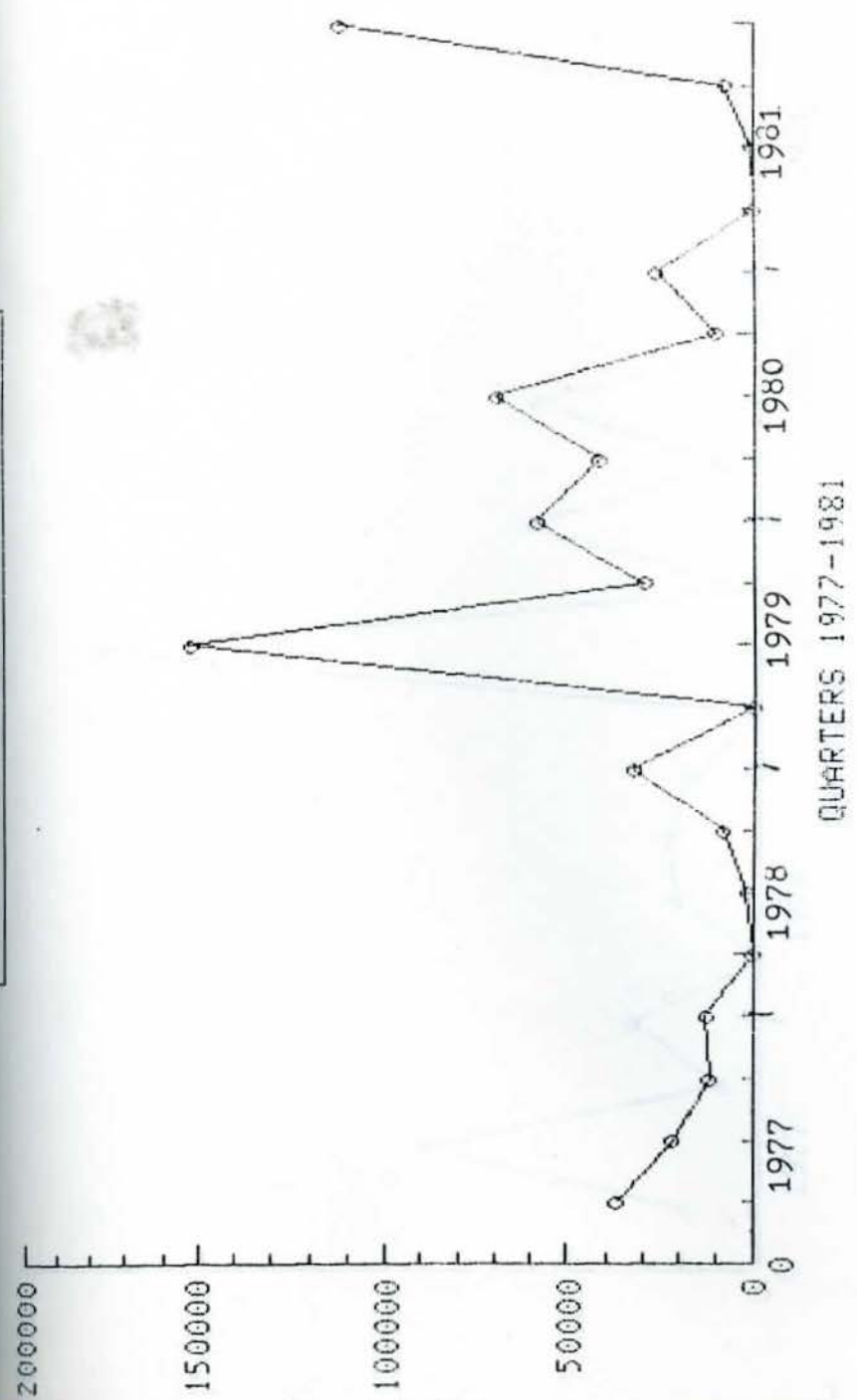

TOTAL DOLLAR SALES BY QUARTER FOR ROMAN

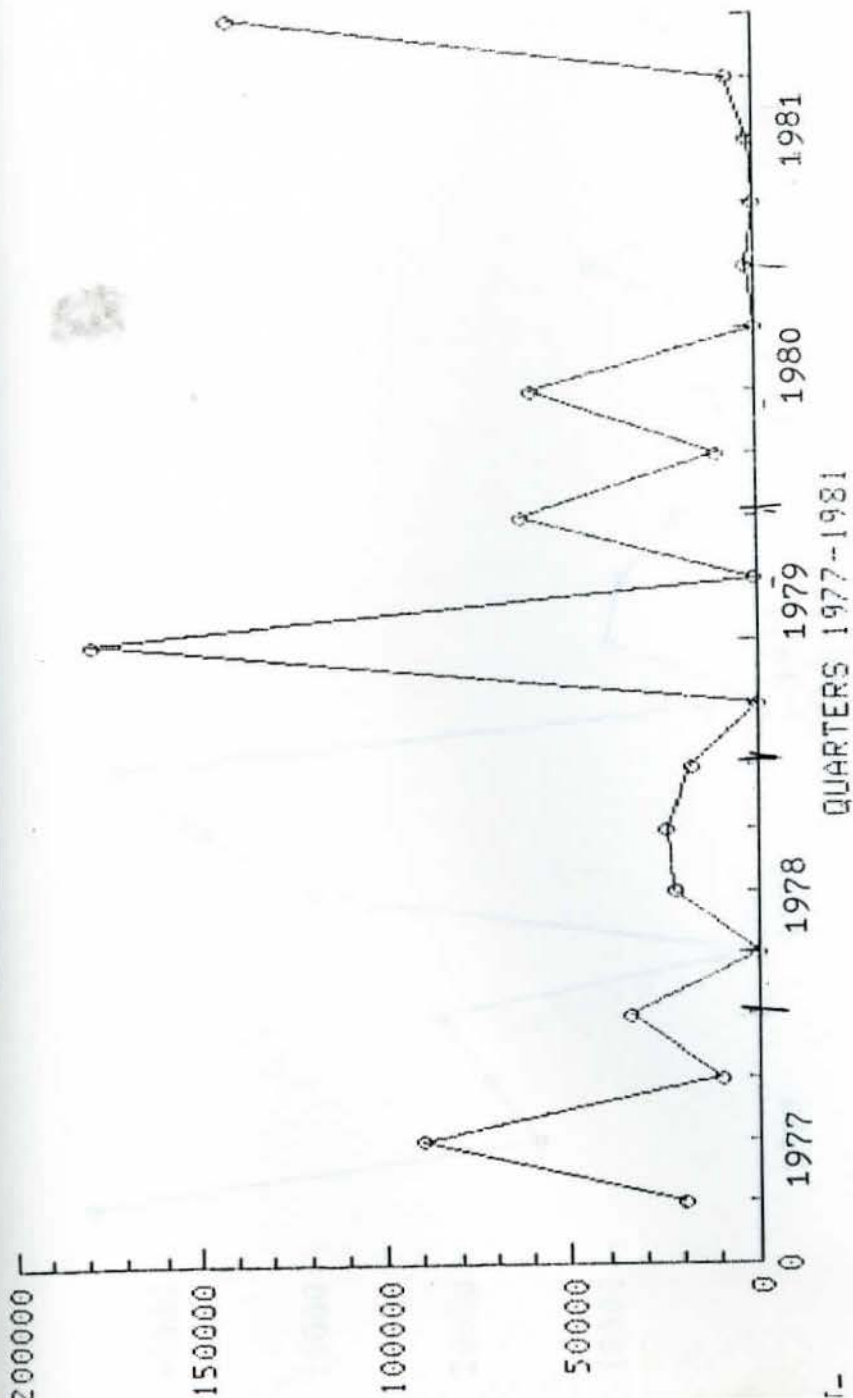

AVERAGE DOLLAR SALES BY QUARTER FOR EGYPT

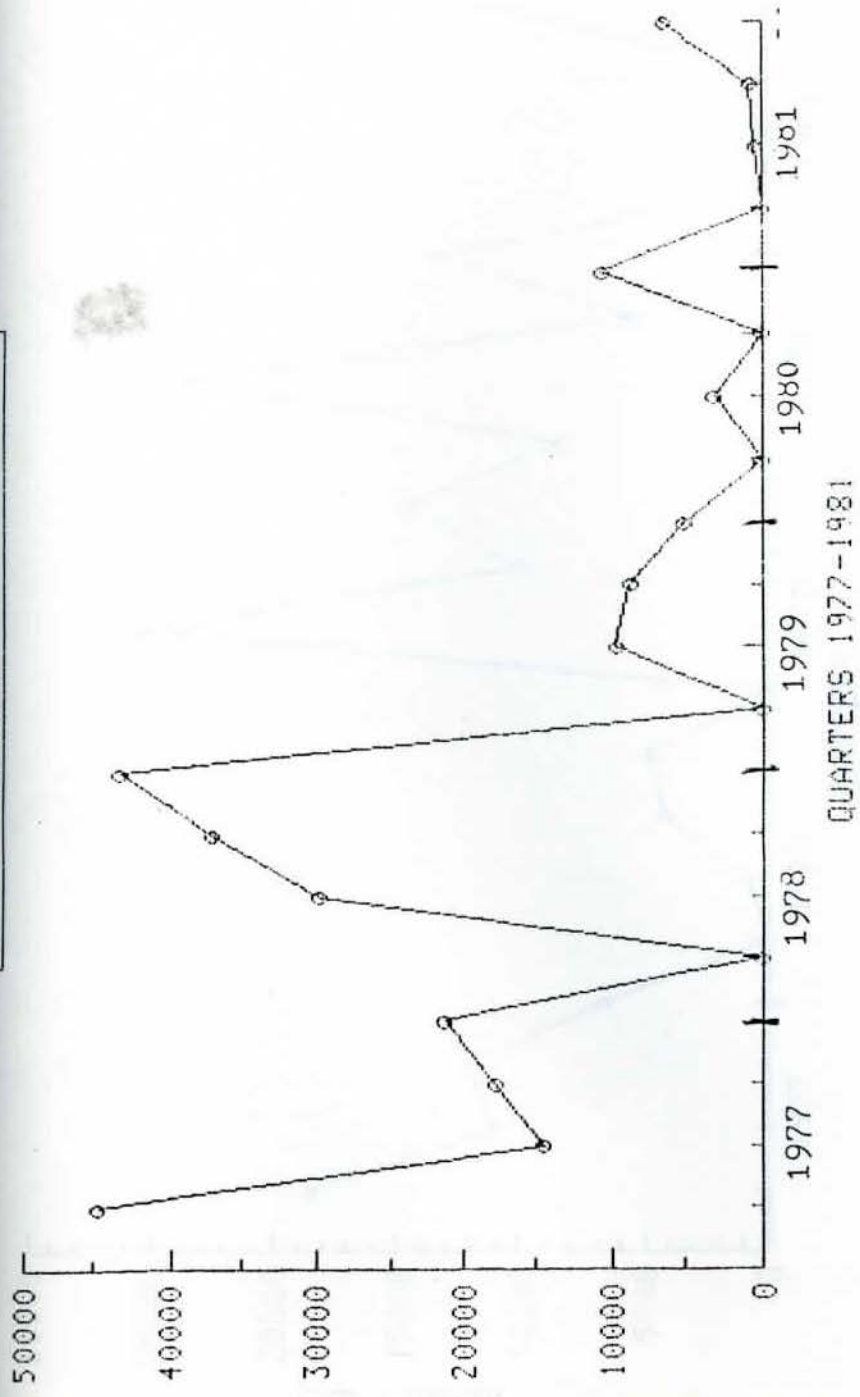

AVERAGE DOLLAR SALES BY QUARTER FOR GREECE

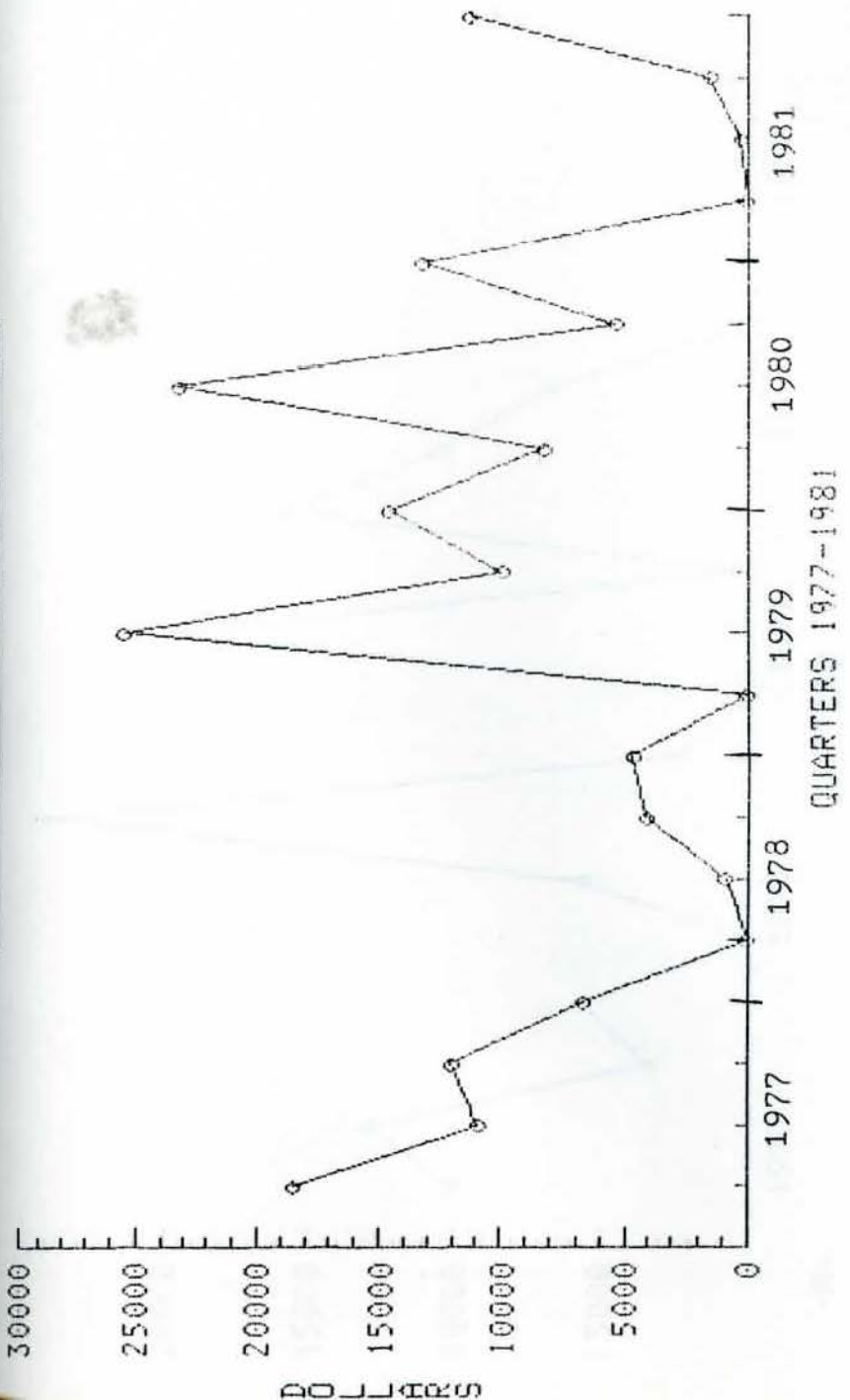

AVERAGE DOLLAR SALES BY QUARTER FOR ROMAN

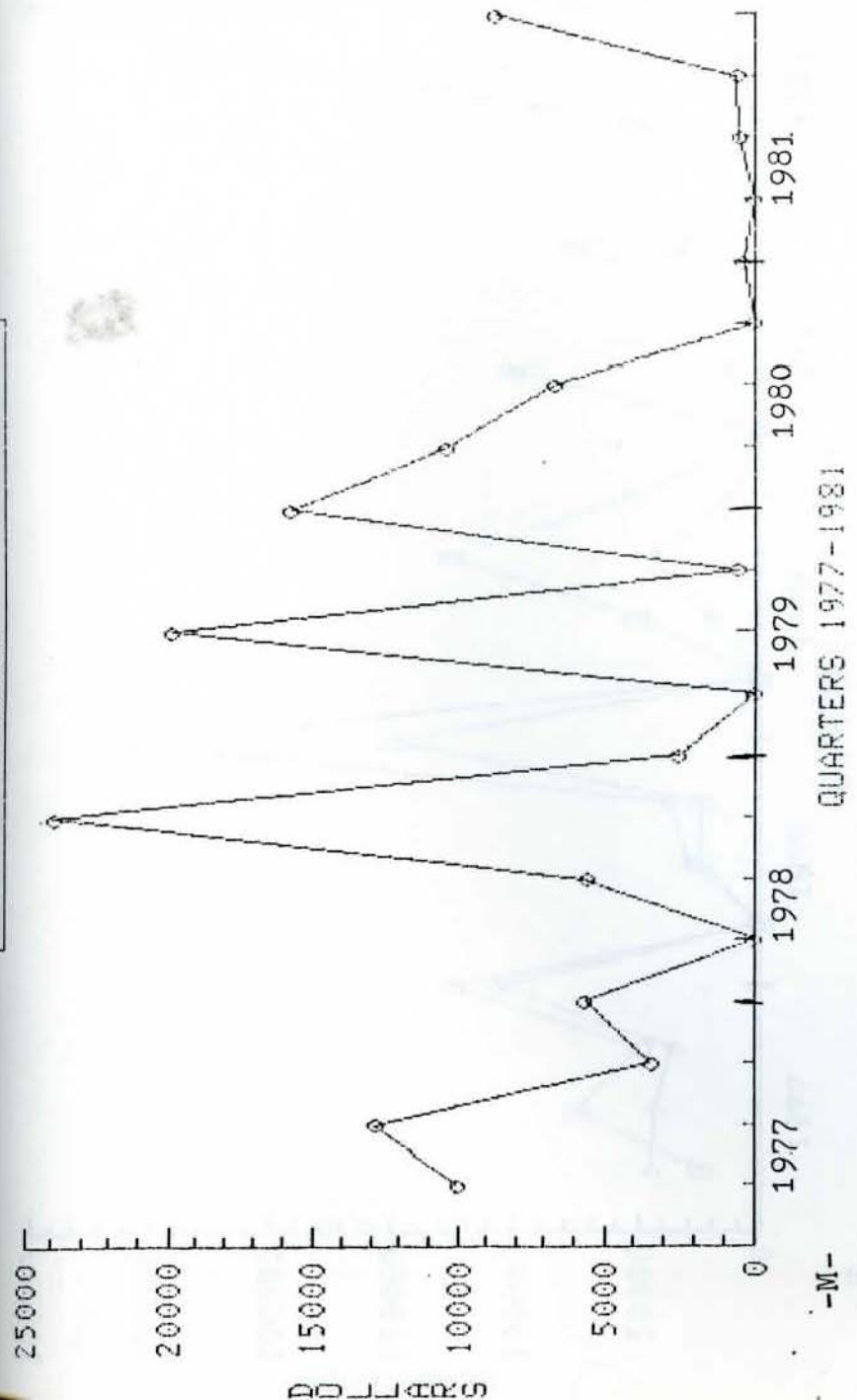

▲ DOLLARS  
 ■ NUMBER OF ITEMS

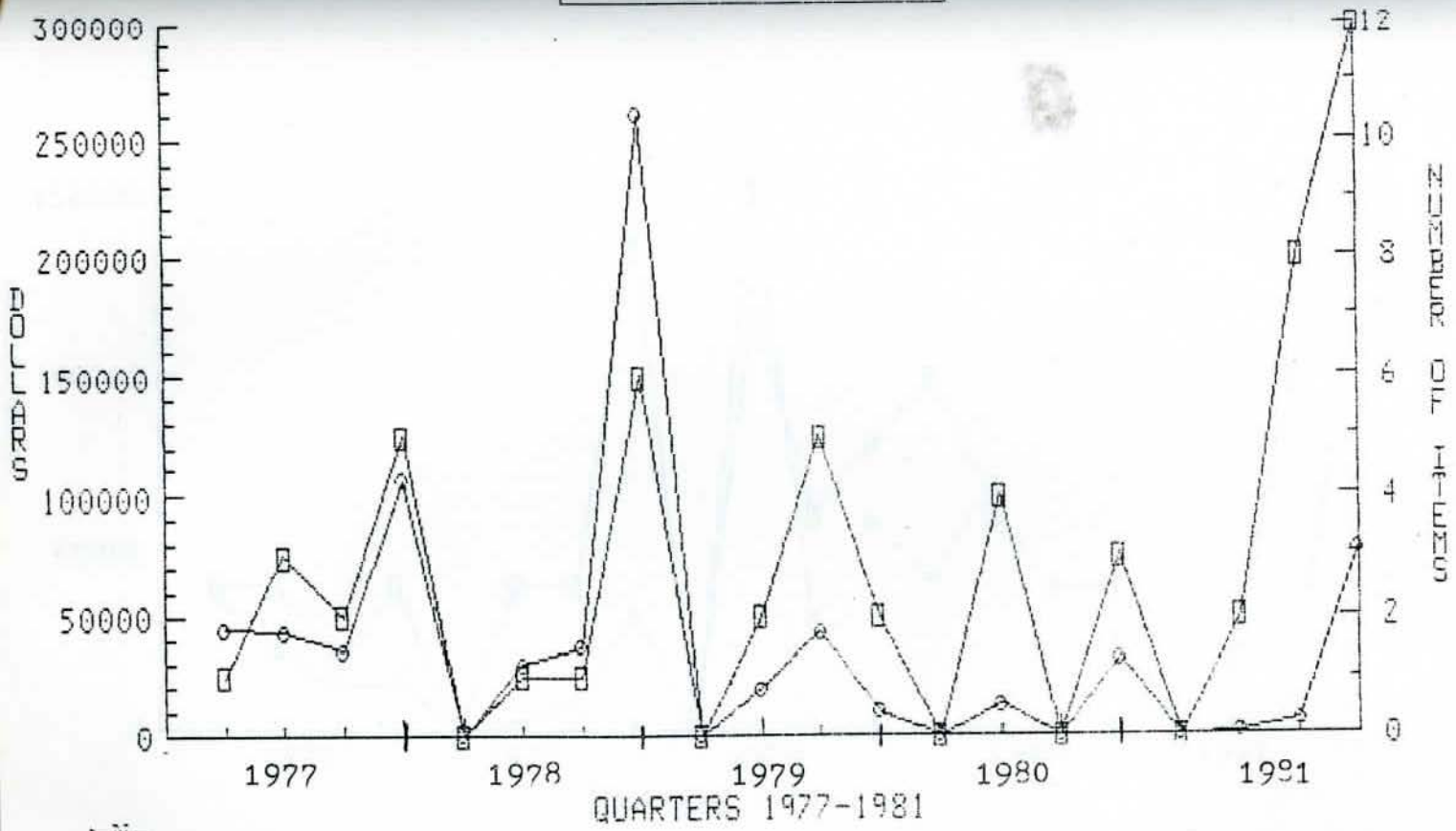

—○— POLYMER OF ITEMS  
—□— NUMBER OF ITEMS

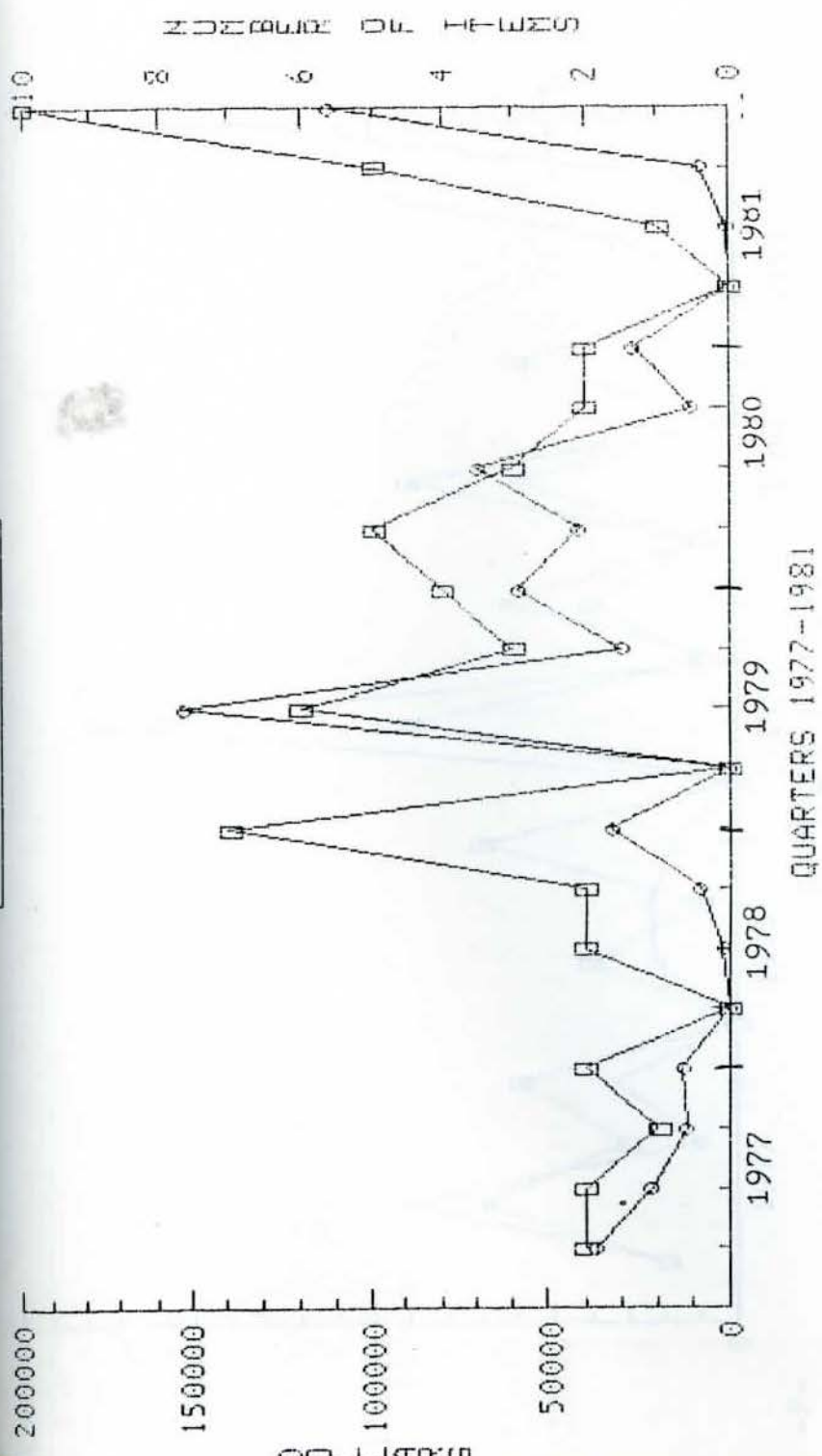



—○— NUMBER OF ITEMS  
—□— NUMBER OF HEADS

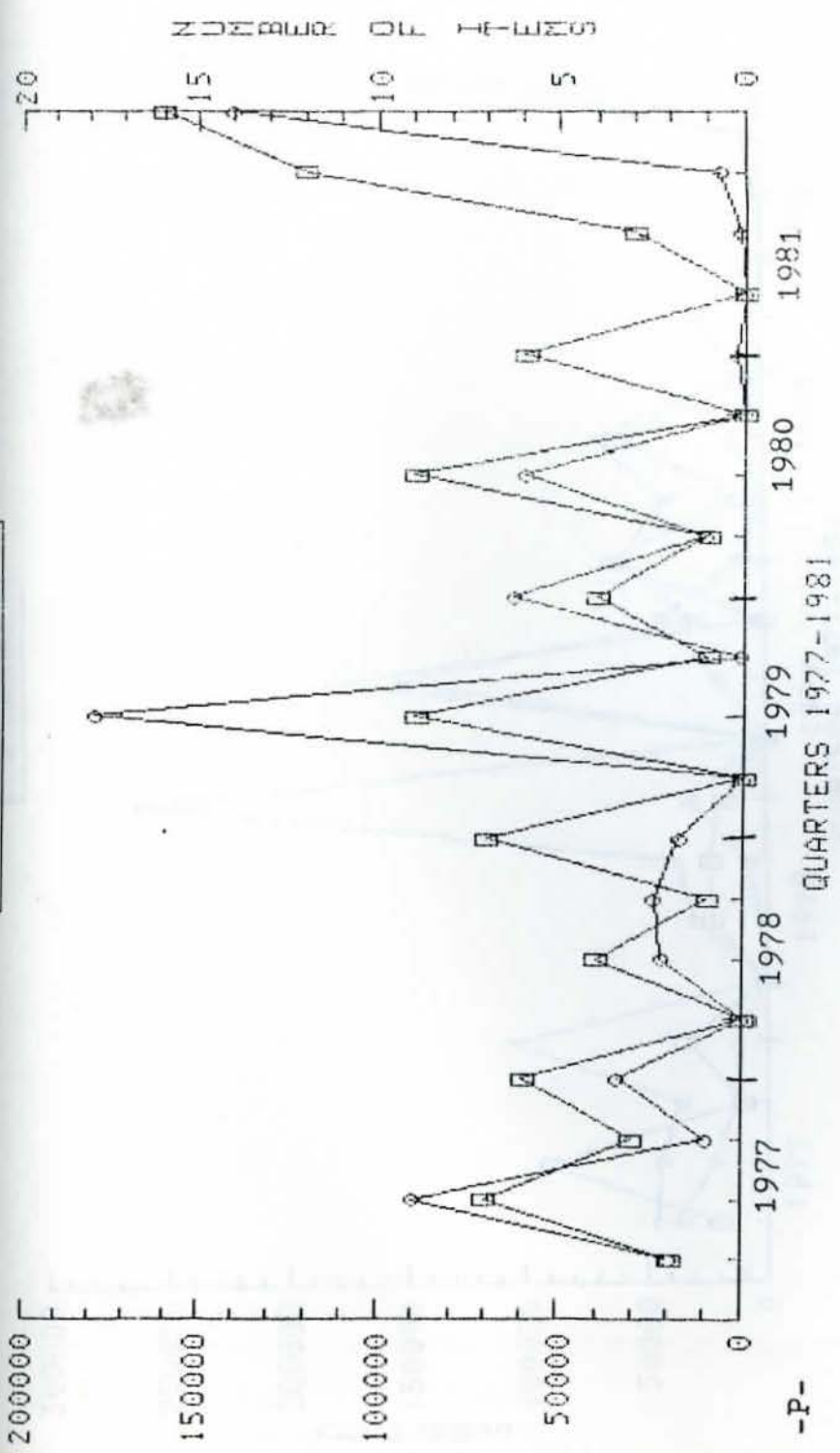

GREECE  
GREECE  
ROMAN

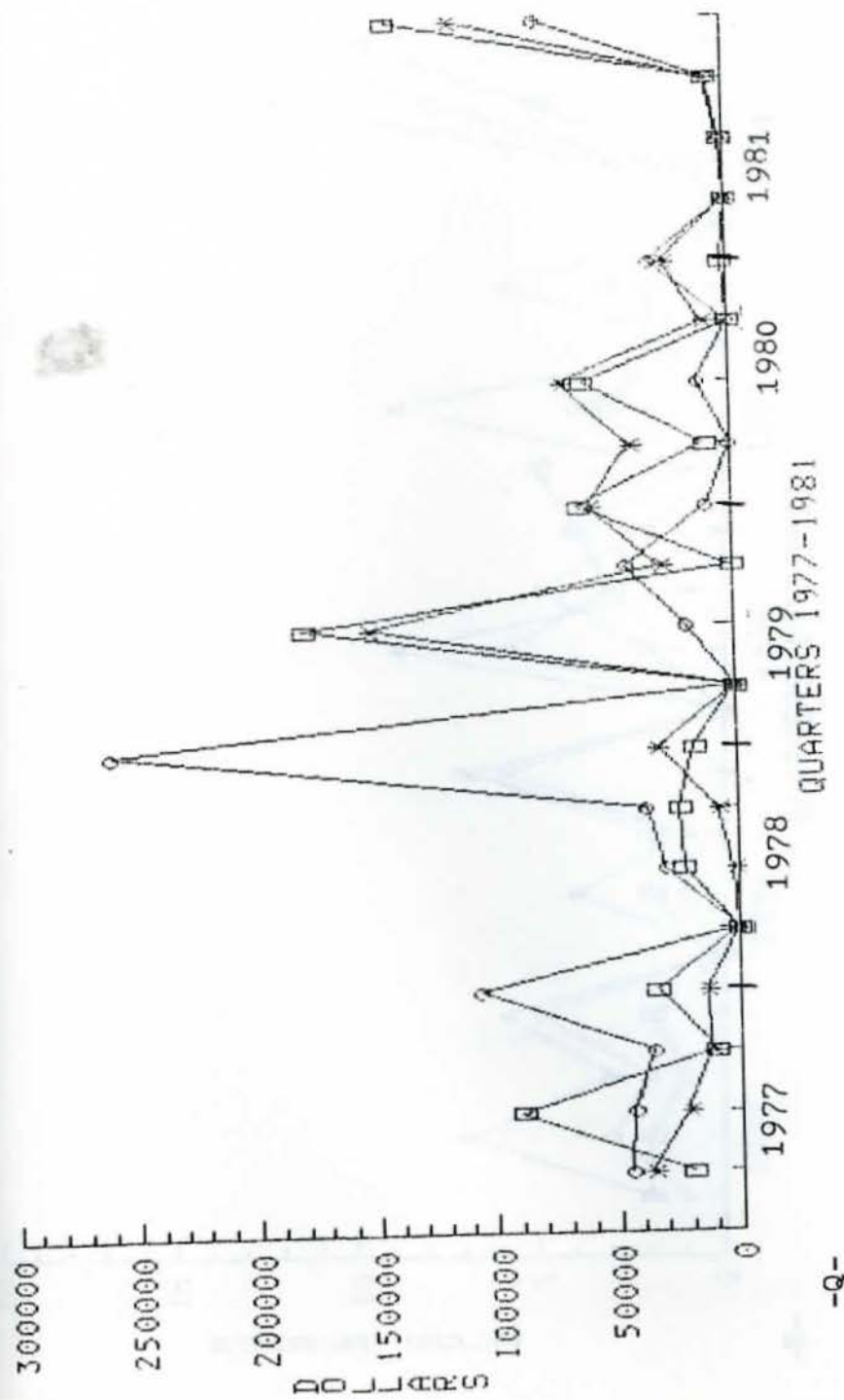

— GREECE  
— ROMAN

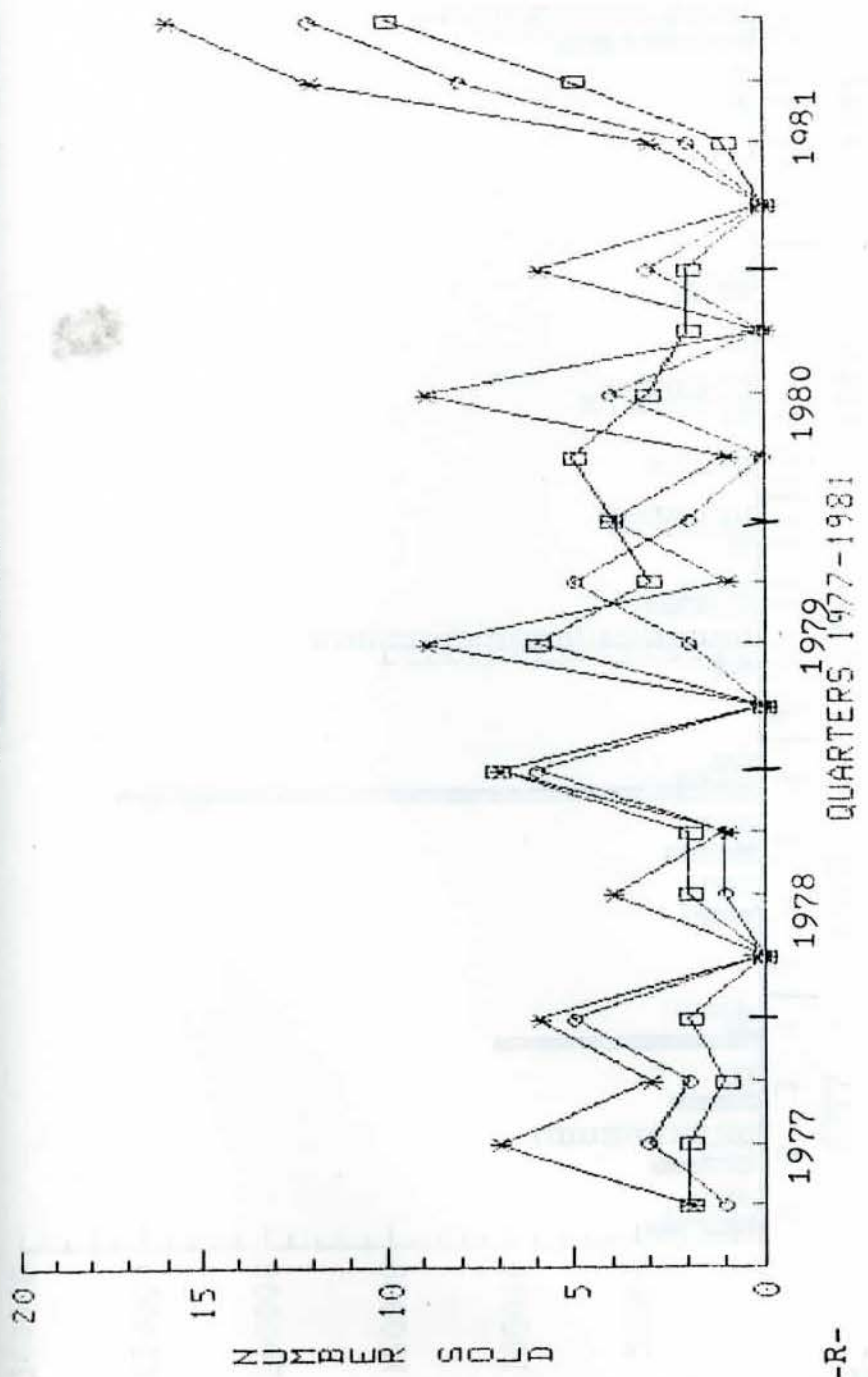

EGYPT  
GREECE  
ROMAN

QUARTERS 1977-1981

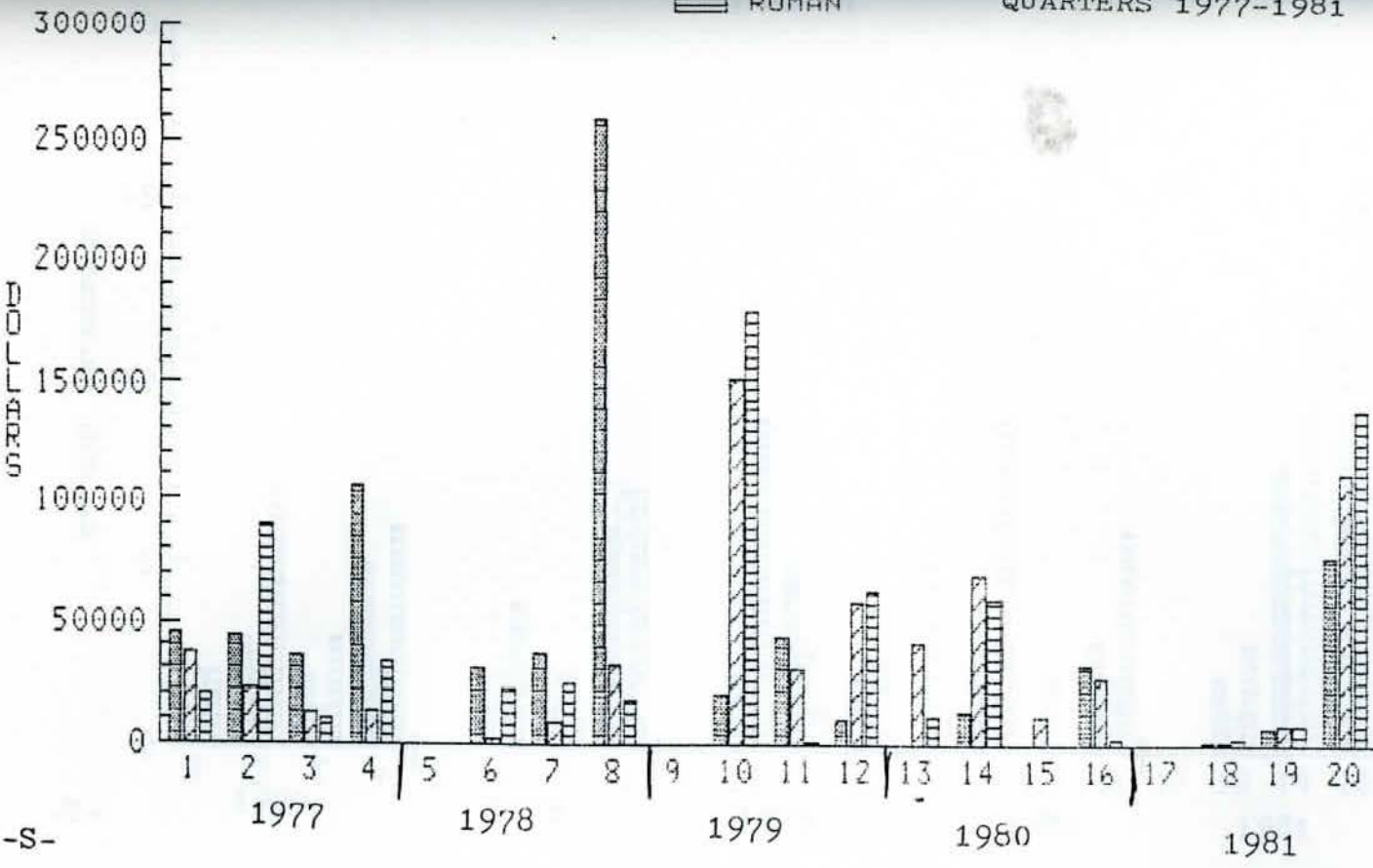

-S-

EGYPT  
GREECE  
ROMAN

QUARTERS 1977-1981

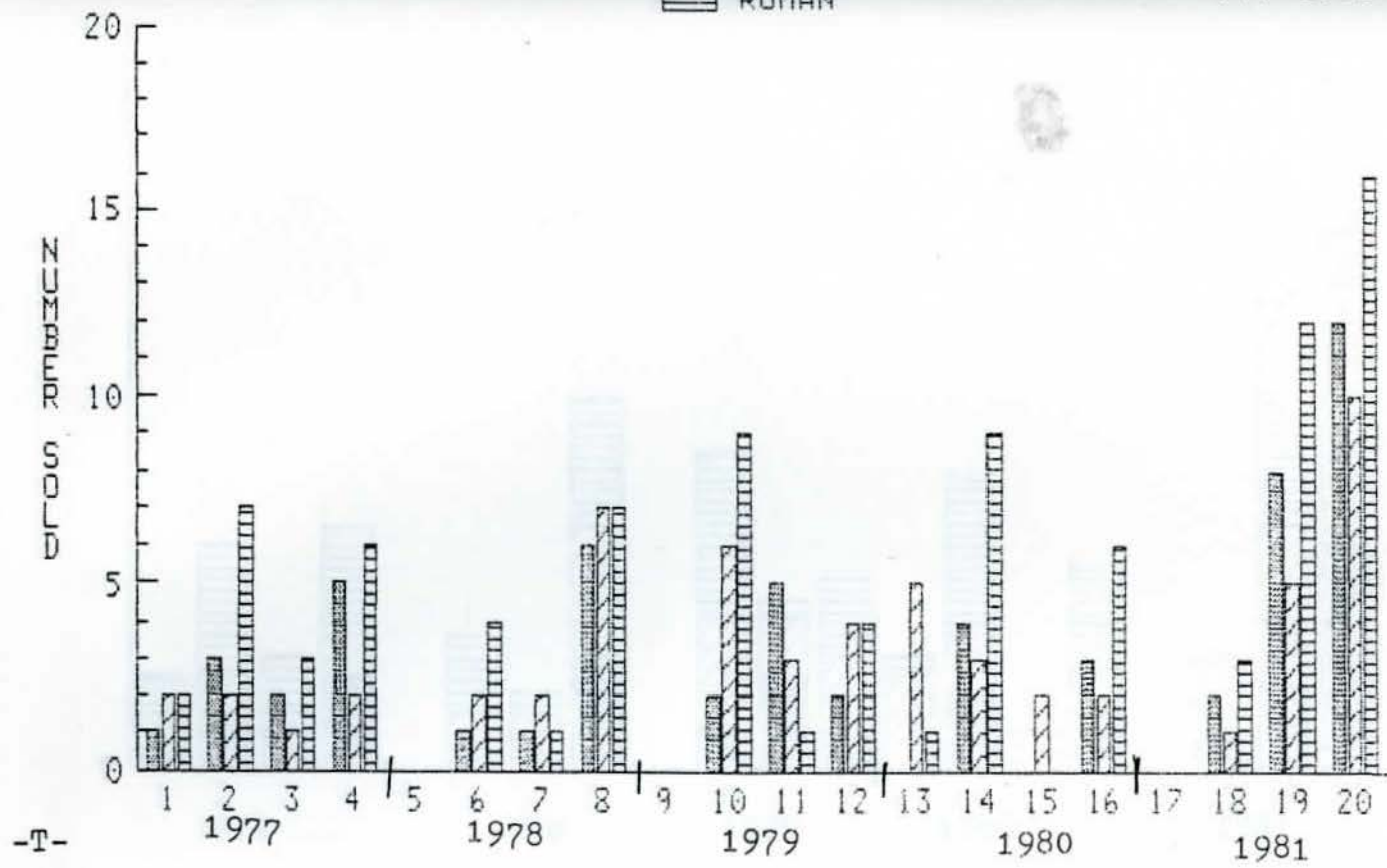

SOVIET QUARTERS 1977-1981

GREECE  
ROMAN

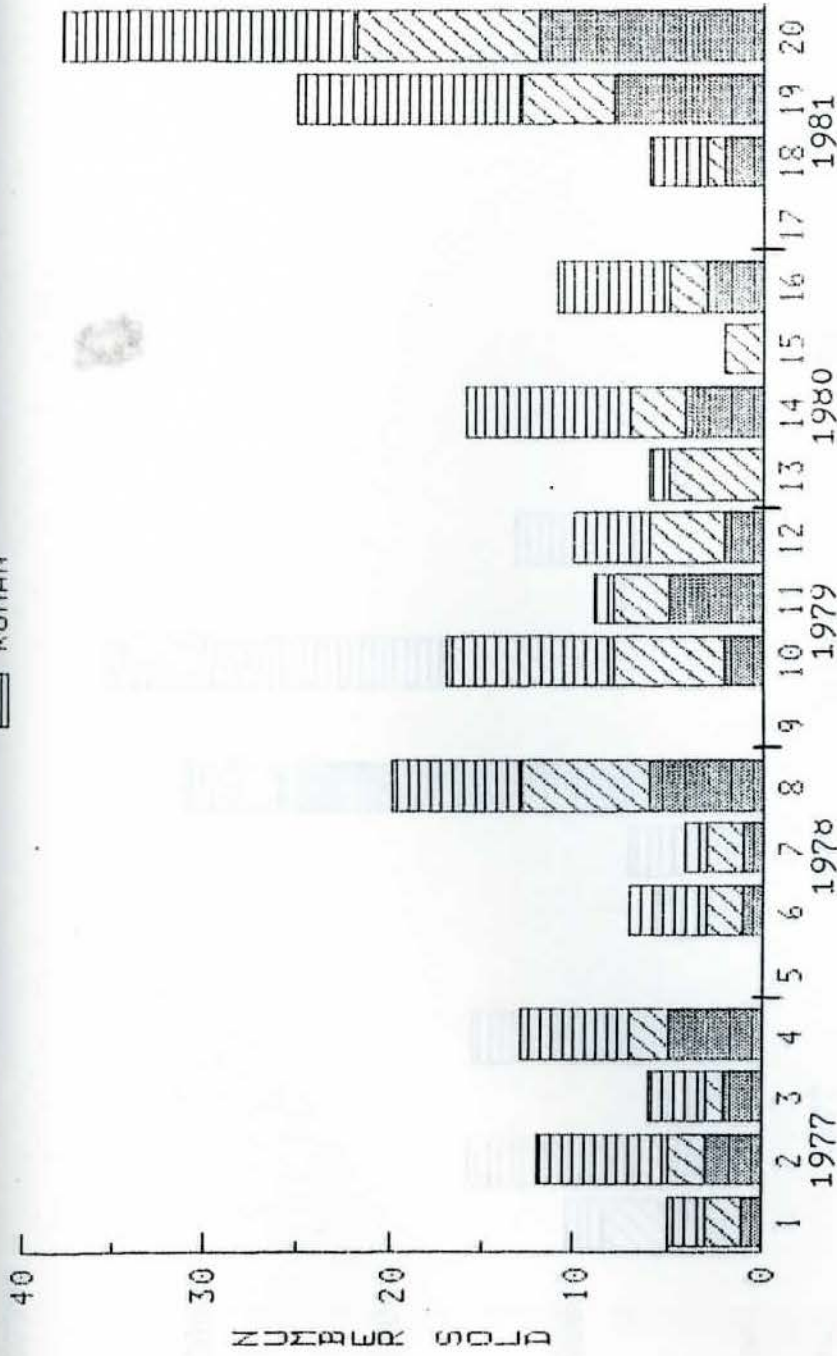

EGYPT  
GREECE  
ROMAN

QUARTERS 1977-1981

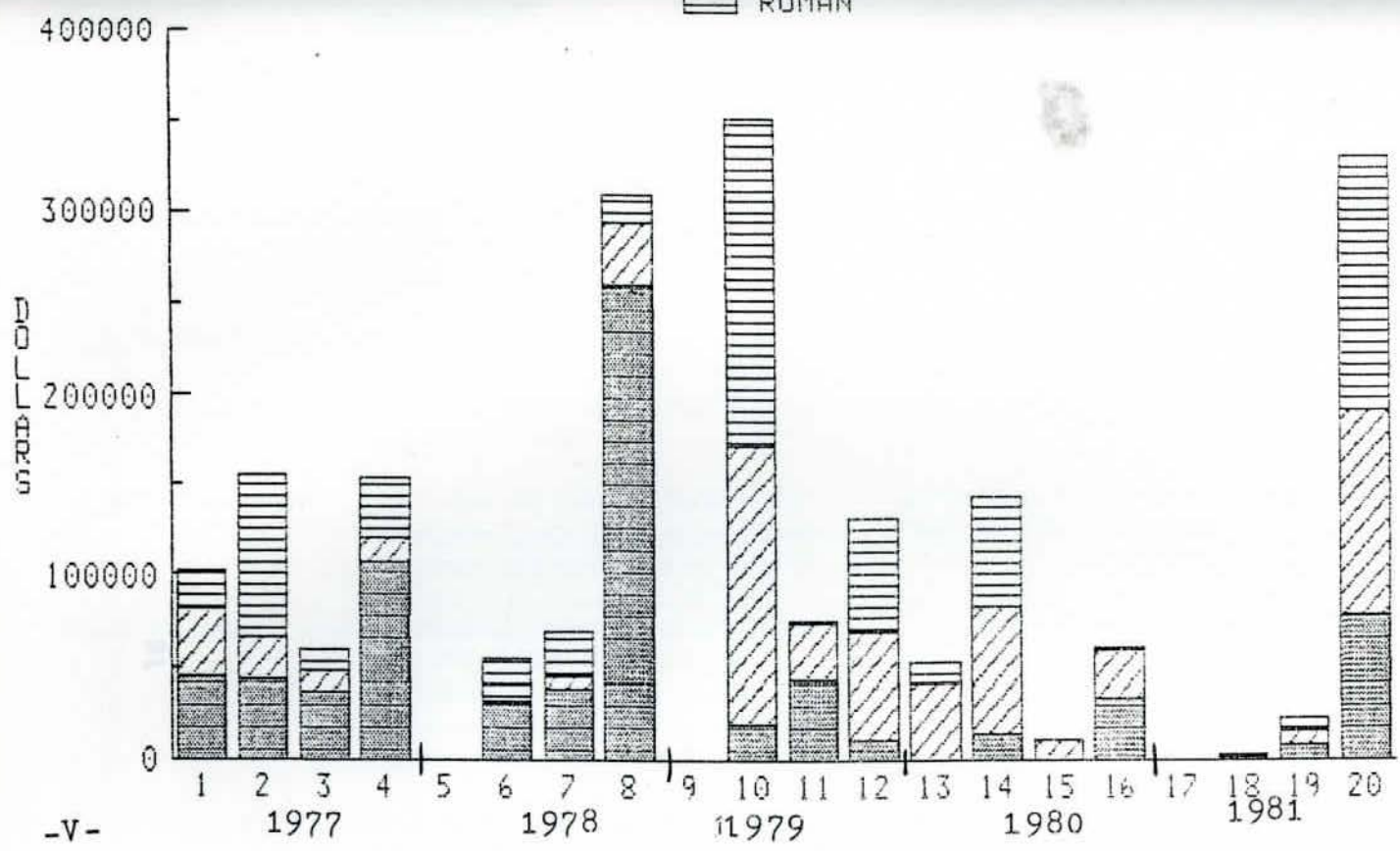

-v-

### APPENDIX III

#### SALES RESULTS AND RATING

May, June, and July 1982



PIECE	DESCRIPTION	SELLER	ESTIMATE	SELLING PRICE	RATE
Egyptian Sculpture	Bronze figure of a king; late period 712-30 BC; in striding position with headdress; height: 7½"	SPB, New York; May 20, 1982; No. 49	\$5,000-\$8,000	Bought in	6
Egyptian Sculpture	Bronze figure of a cat; 22nd-26th Dynasty; 946-525 BC; full length seated figure of a cat; height: 4"	SPB, New York; May 20, 1982; No. 54	\$3,000-\$4,000	Bought in	5
Egyptian Sculpture	Alabaster head of a man; late dynastic period, circa 1000-300 BC; in archaic style; height: 3½"; condition: worn	SPB, New York; May 20, 1982; No. 72	\$1,500-\$2,500	Bought in	5
Egyptian Sculpture	Limestone sculptors model; 30th dynasty to early Ptolemaic period, circa 380-200 BC; height: 3-7/8"	SPB, New York; May 20, 1982; No. 74	\$1,200-800	\$1,760	6 fine quality, clearly sculpted
Greek Ceramic	Attic black figure panel Amphora; circa 550-540 BC; depicting charioteer and warrior on one side, a similar scene on the other side; height: 14¼"	SPB, New York; May 20, 1982	\$3,000-4,000	Bought in	5
Greek Ceramic	Attic black figure neck Amphora; circa 520-510 BC; one side depicting Herakles in combat, other side with three warriors; height: 15-3/4"; references	SPB, New York; May 20, 1982; No. 92a	\$8,000-12,000	Bought in	5
Greek Ceramic	Attic red figure Nolan Amphora; circa mid-5th century BC; painted with Dionysos walking; height: 11-9/16"; references	SPB, New York; May 20, 1982; No. 95	\$8,000-12,000	\$11,000	6 good condition
Greek Ceramic	Attic red figure Hydria; circa 470-460 BC; with disc foot and painted with figure of Poseidon; height: 13"	SPB, New York; May 20, 1982; No. 99	\$7,000-10,000	\$11,000	6

PIECE	DESCRIPTION	SELLER	ESTIMATE	SELLING PRICE	RATE
Greek Ceramic	Attic red figure column crater; circa 480-460 BC; one side with figures of goat and deer; height: 11"	SPB, New York; May 20, 1982; No. 102	\$4,000-6,000	\$4,180	6 expertly sculpted
Greek Ceramic	Attic red figure Kylix; circa 400-375 BC; exterior with athletes in various positions, interior with Eros riding a dolphin (one handle and much of foot restored); rim diameter: 9-3/8"; provenance; attribution	SPB, New York; May 20, 1982; No 106	\$3,000-5,000	\$3,410	10 because of attribution
Greek Ceramic	Attic black-glaze stemless Kylix; first half 5th century; rim diameter: 8-9/16"; provenance	SPB, New York; May 20, 1982; No. 109	\$1,200-1,800	\$1,320	6 black-glaze highly desirable
Greek Ceramic	Pair of black-glaze Volute Kraters with stands, south Italy; last quarter of the 4th century BC; each with ribbed bodies; total heights: approx. 39"; references	SBP, New York; May 20, 1982	\$30,000-40,000	\$33,000	8 highly desirable, especially since pair
Greek Sculpture	Cycladic marble goddess; early Bronze Age II; circa 2700-2500 BC; height: 7-1/8"; references	SPB, New York; May 20, 1982; No. 119	\$8,000-12,000	Bought in	9 extremely rare and highly desirable piece
Greek Ceramic	Terra cotta head of a youth; height: 10"; references	SPB, New York; May 20, 1982; No. 124	\$20,000-30,000	\$13,200	6 could be a highly desirable but is very stylized and not typical
Greek Sculpture	Fragment of an Attic marble Stele; circa early 4th century BC; depicting bearded man with downcast eyes; height in front: 15-3/8"	SPB, New York; May 20, 1982, No. 131	\$20,000-\$30,000	\$16,500	8 highly desirable piece; also depicted on cover of of catalogue

PIECE	DESCRIPTION	SELLER	ESTIMATE	SELLING PRICE	RATE
Greek Sculpture	Scene from an Attic marble grave Stele; circa 375-350 BC; carved in shallow relief with woman, girl, and bearded man; 15-1/8" x 17-3/8"	SPB, New York; May 20, 1982	\$10,000-15,000	Bought in	7 could be desirable, except quality of sculpturing extremely poor
Greek Sculpture	Marble head of a Hellenistic prince; circa 1st century BC-AD; height: 18"; provenance; references	SPB, New York; May 20, 1982	\$30,000-50,000	\$22,000	8 portraiture desirable
Roman Sculpture	Marble torso of a god or athlete; 1st-2nd century AD, after Greek original; height: 34"; references	SPB, New York; May 20, 1982; No. 138	\$40,000-60,000	\$30,000	8 beautifully sculpted
Roman Sculpture	Marble figure of Pan; circa second half 1st century AD; after Hellenistic work (large areas missing); height: 26-5/8"	SPB, New York; May 20, 1982	\$40,000-60,000	\$48,400	8 Baroque period; desirable
Greek Sculpture	Marble figure of a goddess; Hellenistic; circa 3rd century BC-1st century AD; height: 21-3/8"; references; provenance	SPB, New York; May 20, 1982; No. 144	\$6,000-9,000	\$4,400	7
Roman Sculpture	Marble head of a goddess; circa 2nd century AD; over life-size depiction of woman; height: 7 1/2"	SPB, New York; May 20, 1982	\$30,000-50,000	\$33,000	9
Roman Sculpture	Bronze bust of a man; first half 1st century AD; perhaps a member of the Julio-Claudian family; height: 8-3/8"; provenance; references	SPB, New York; May 20, 1982	\$20,000-30,000	\$13,200	8
Roman Sculpture	Marble portrait of a boy; 1st century AD; height of head: 3-3/8"; references	SPB, New York; May 20, 1982; No. 156	\$3,000-5,000	\$2,200	6

PIECE	DESCRIPTION	SELLER	ESTIMATE	SELLING PRICE	RATE
Greek Ceramic	Apulian red figure, Bell Krater; late 4th century BC; depicting Eros and maiden; diameter: 17 $\frac{1}{4}$ "	SPB, New York; May 20, 1982; No. 181	\$1,500-2,500	Bought in	5
Greek Ceramic	Apulian red figure, Volute Krater; circa 330-300 BC; one side with nude woman, other side with three male figures; height: 25-3/4"; possible attribution	SPB, New York; May 20, 1982; No. 184	\$2,000-3,000	\$2,200	5
Greek Ceramic	Red figure fish plate; late 4th century BC; diameter: 8 $\frac{1}{4}$ "	SPB, New York; May 20, 1982; No. 188	\$800-1,200	\$1,320	5 common piece
Roman Glass	Bluish-green glass vase; 2nd-3rd century AD; having tapering body; height: 7 $\frac{1}{2}$ "	SPB, New York; May 20, 1982; No. 213	\$1,000-1,500	\$800	5

The following items from Joel L. Malter & Co. are not illustrated; rating is difficult. Also, it is not known whether amount is final sales result or suggested estimate.

Roman Glass	Short pitcher of pale green glass; some iridescence; height: 2-5/8"; no period given	JLM, Encino, CA; June 6, 1982; No. 90	\$300		4
Roman Glass	Aqua glass flask with iridescence; height: 4-5/8"	JLM, Encino, CA; June 6, 1982; No. 96	\$200		4
Roman Glass	Pale aquamarine bottle with iridescence; height: 7-1/8"	JLM, Encino CA; June 6, 1982; No. 103	\$500		4
Roman Glass	Footed vase with iridescence; good condition; height: 6-3/4"	JLM, Encino, CA; June 6, 1982; No. 109	\$1,000		4
Roman Glass	Pale blue vase with flared neck; height: 5 $\frac{1}{2}$ "	JLM, Encino, CA; June 6, 1982; No. 124	\$400		4

PIECE	DESCRIPTION	SELLER	ESTIMATE	SELLING PRICE	RATE
Roman Glass	Unguentarium of pale blue glass; height: 4 $\frac{1}{4}$ "	JLM, Encino, CA; June 6, 1982; No. 126	\$300		4
Roman Glass	Pale green flask with square body and iridescence; height: 4-1/8"	JLM, Encino, CA; June 6, 1982; No. 130	\$325		4
Egyptian Sculpture	Bronze statue of an Apis bull; height: 4 cm; 26th dynasty	JLM, Encino, CA; June 6, 1982; No. 153	\$200		4
Greek Ceramic	South Italian black figure Lekythos; height: 13 cm; 5th-4th century BC	JLM, Encino, CA; June 6, 1982; No. 173	\$250		5
Greek Ceramic	Greek black-glazed Kantharos; height: 6.2 cm; late 5th century BC	JLM, Encino, CA; June 6, 1982; No. 176	\$100		5
Greek Ceramic	Mycenean stirrup jar with some restoration; height: 3-1/8, 4 $\frac{1}{4}$ " diameter	JLM, Encino, CA; June 6, 1982; No. 183	\$450		4 because of condition
Greek Sculpture	Hellenistic marble head of a man wearing a wreath; height: 5.8 cm; 3rd-2nd century BC	JLM, Encino, CA; June 6, 1982; No. 189	\$350		5
Greek Ceramic	Greek terra cotta pitcher; restorations; height: 8-7/8"	JLM, Encino, CA; June 6, 1982; No. 197	\$150		4
Greek Ceramic	South Italian red figure fish plate; circa 330-310 BC; diameter: 7-5/8"	GLJ, La Jolla, CA; March 1982		\$1,500	4
Egyptian Sculpture	Bronze figure of kneeling male; late period (715-330 BC); height: 3"	RAG, New York March 1982		\$2,000	4

PIECE	DESCRIPTION	SELLER	ESTIMATE	SELLING PRICE	RATE
Egyptian Sculpture	Bronze figure of Isis; 25th-30th dynasty (664-343 BC); height: 8 $\frac{1}{4}$ "	RAG, New York; March 1982		\$4,500	5 good condition
Egyptian Sculpture	Bronze seated figure of Horus; Ptolemaic period (323-30 BC); height: 6"	RAG, New York; March 1982		\$2,750	5
Egyptian Sculpture	Bronze seated figure of Isis; late 25th-26th dynasty (circa 625-525 BC); height: 3 $\frac{1}{2}$ "	RAG, New York; March 1982		\$2,000	4 poor condition
Egyptian Sculpture	Steatite standing male figure; 11th-12th dynasty (2040-1785 BC); height: 4-5/8"	RAG, New York; March 1982		\$1,750	6 nice piece
Egyptian Sculpture	Bronze bust of a cat; late period (712-30 BC); height: 3 $\frac{1}{2}$ "	RAG, New York; March 1982		\$2,500	
Egyptian Sculpture	Painted wood figure of a female; 11th-12th dynasty (2040-1785 BC); height: 10 $\frac{1}{4}$ "	RAG, New York; March 1982		\$5,000	6 good condition
Greek Ceramics	Hellenistic terra cotta figure of a woman; 3rd century BC; height: 9-5/8"	SPB, New York; May 26, 1982; No. 424	\$500-800	\$330	4
Greek Ceramics	Apulian red figured Amphora with one panel depicting hero; circa 330 BC; height: 20"	AEG, New York; June 1982	\$6,000		5
Roman Glass	Aubergine glass octagonal flask; height: 2-3/4"; 1st century AD	Christies, London; July 2, 1982; No. 5	350-450£/ \$630-810	302£/ \$529	4
Egyptian Sculpture	Black granite head of a pharaoh; height: 5 $\frac{1}{2}$ "; late new kingdom	Christies, London; July 2, 1982; No. 142	1,000-1,500£/ \$1,440-2,160	bought in	5

PIECE	DESCRIPTION	SELLER	ESTIMATE	SELLING PRICE	RATE
Egyptian Sculpture	Bronze figure of a seated cat; height: 4½"; late period	Christies, London; July 2, 1982; No. 172	800-1,200£/ \$1,440-2,160	1,350£/ \$2,363	5
Egyptian Sculpture	Bronze seated cat; height: 6¼" high; late 7th, early 6th century BC	Christies, London; July 2, 1982; No. 173	2,000-3,000£/ \$3,600-5,400	3,456£/ \$6,048	5
Egyptian Sculpture	Basalt block statue of a seated official; late 25th-26th dynasty; references	Christies, London; July 2, 1982; No. 179	4,000-5,000£/ \$7,200-9,000	4,320£/ \$7,560	6
Egyptian Sculpture	Rare bronze figure of Seth; height: 6-3/4"; late new kingdom	Christies, London; July 2, 1982; No. 180	5,000-6,000£/ \$9,000-10,800	bought in	8 rare piece
Egyptian Sculpture	Brown hardstone head of Egyptian official; inscribed; height: 10"; circa 7th century BC	Christies, London; July 2, 1982; No. 181	7,000-10,000£/ \$12,600-18,000	7,020£/ \$12,285	7
Roman Sculpture	Bronze figure of Venus standing naked; height: 4½"; 2nd-3rd century AD	Christies, London; July 2, 1982; No. 193a	150-200£/ \$270-370	1,080£/ \$1,890	5
Roman Sculpture	Bronze figure of Athena standing; height: 4½"; 1st-2nd century AD	Christies, London; July 2, 1982; No. 196	300-500£/ \$540-900	702£/ \$1,229	4
Greek Ceramic	Apulian red figure fish plate (from the Phrixos Group); diameter: 9"; 4th century BC	Christies, London; July 2, 1982; No. 203	500-600£/ \$900-1,050	648£/ \$1,134	4
Greek Ceramic	South Italian red figure Calyx Krater depicting three youths reclining on couch; height: 11¼"; 4th century BC	Christies, London; July 2, 1982; No. 205	500-700£/ \$900-1,050	bought in	5

PIECE	DESCRIPTION	SELLER	ESTIMATE	SELLING PRICE	RATE
Greek Ceramic	Terra cotta figure of a draped female; restorations; height: 5½"; mid-4th century BC	Christies, London; July 2, 1982; No. 212	250-300£/ \$450-500	302£/ \$529	4
Greek Ceramic	Attic black figure, tripod Pyxis with animal motifs; height: 3¼", diameter: 5"; late 6th century BC	Christies, London; July 2, 1982; No. 218	400-600£/ \$720-1,080	1,134£/ \$1,985	4 because of restorations
Roman Sculpture	Marble torso of Venus; height: 25½"; circa 1st century AD	Christies, London; July 2, 1982; No. 231	3,000-4,000£/ \$4,500-7,200	1,944£/ \$3,402	6
Greek Ceramic	Attic red figure fish plate by the Scorpion fish painter with three fish; diameter: 9½"; circa 370-360 BC	Christies, London; July 2, 1982; No. 240	600-800£/ \$1,080-1,440	1,620£/ \$2,835	4
Greek Ceramic	Attic black-glazed Kylix; diameter: 12¼"; mid-5th century BC	Christies, London; July 2, 1982; No. 244	400-500£/ \$720-900	bought in	5 black-glaze desirable
Greek Ceramic	Little Master lip cup with swan motif; diameter: 11"; late 6th century BC	Christies, London; July 2, 1982; No. 249	2,000-3,000£/ \$3,600-5,400	bought in	7 desirable
Greek Ceramic	Attic black figure Siana cup by the C painter with animal and men motif; diameter: 13½"; second quarter 6th century BC	Christies, London; July 2, 1982; No. 250	3,500-4,500£/ \$6,300-8,100	bought in	
Roman Glass	Bluish-green glass jug having pear shape and strap handle; height: 7¼"; circa 3rd century AD	S, London; July 5, 1982; No. 18	450-600£/ \$810-1,170	bought in	5
Roman Glass	Yellowish-green square glass flask with strap handle; height: 5¼"; 2nd-3rd century AD	S, London; July 5, 1982; No. 19	150-200£/ \$270-360	165£/ \$289	4
Roman Glass	Dark blue ribbed glass bowl; diameter: 5"; 1st century AD	S, London; July 5, 1982; No. 21	1,000-1,500£/ \$1,800-2,700	2,640£/ \$4,620	6 fairly unusual



PIECE	DESCRIPTION	SELLER	ESTIMATE	SELLING PRICE	RATE
Roman Glass	Pale green glass bowl of shallow rounded form, some iridescence; diameter: 7-1/8"; 1st-2nd century AD	S, London; July 5, 1982; No. 22	800-1,200£/ \$1,440-2,160	bought in	5
Roman Glass	Heavy opaque red cast glass bowl; diameter: 5-5/8"; 1st century BC-1st century AD	S, London; July 5, 1982; No. 23	7,500-10,000£/ \$13,500-18,000	bought in	8 extremely fine
Roman Glass	Unusually large deep amber colored pillar-molded glass bowl; diameter: 8"; 1st century AD; provenance; references	S, London; July 5, 1982; No. 31	5,500-7,500£/ \$9,900-13,500	2,860£/ \$5,000	7 size very rare
Roman Glass	Pale green double-bodied Unguentarium with double-looped trailed handles; height: 6"; circa 4th century AD	S, London; July 5, 1982; No. 36	150-250£/ \$270-450	484£/ \$847	4 common form
Roman Glass	Pale green glass Janus head flask; height: 2-5/8"; circa 3rd century AD	S, London; July 5, 1982; No. 41	200-250£/ \$360-450	198£/ \$346	5
Roman Glass	Large pale green glass flask (interior containing a miniature pale green glass Amphoriskos); height: 13-3/8"; 4th century AD; not perfect condition; provenance; references	S, London; July 5, 1982; No. 50	6,000-10,000£/ \$10,800-18,000	bought in	8 highly unusual form
Egyptian Sculpture	Dark gray stone male head; height: 4 1/4"; new kingdom period	S, London; July 5, 1982; No. 97	400-600£/ \$720-1,080	528£/ \$924	5 small; not in good condition

PIECE	DESCRIPTION	SELLER	ESTIMATE	SELLING PRICE	RATE
Egyptian Sculpture	Limestone pair statue with two kneeling male figures; height: 13-5/8"; new kingdom period from Thebes	S, London; July 5, 1982; No. 101	2,000-3,000£/ \$3,600-5,400	4,400£/ \$7,700	7
Egyptian Sculpture	Basalt male bust; height: 7 1/2"; late 26th dynasty, circa 600-525 BC	S, London; July 5, 1982; No. 123	1,500-2,500£/ \$2,700-4,500	bought in	7
Egyptian Sculpture	Bronze seated male figure; height: 8 1/2"; 26th dynasty	S, London; July 5, 1982; No. 105	1,200-1,500£/ \$2,160-2,700	bought in	5
Egyptian Sculpture	Small dark gray stone male figure; height: 5-5/8"; middle kingdom	S, London; July 5, 1982; No. 149	200-300£/ \$360-450	462£/ \$808	4 very common
Egyptian Sculpture	Bronze seated figure of Hippocrates; height: 6-1/8"; 26th dynasty	S, London; July 5, 1982; No. 172	400-600£/ \$720-1,080	770£/ \$1,348	5
Egyptian Sculpture	Bronze group of Isis and Horus; height: 12-3/4"; 26th dynasty	S, London; July 5, 1982; No. 173	15,000-18,000£/ \$27,000-32,400	bought in	8 pristine
Egyptian Sculpture	Bronze figure of a cat; height: 9"; late period	S, London; July 5, 1982; No. 177	4,500-6,500£/ \$8,100-11,700	bought in	5
Egyptian Sculpture	Dark brown granite male figure seated; height: 10"; middle kingdom	S, London; July 5, 1982; No. 188	10,000-12,000£/ \$18,000-21,600	bought in	7
Egyptian Sculpture	Bronze figure of Somtous seated; height: 9 1/4"; 26th-30th dynasty (664-342 BC)	S, London; July 5, 1982; No. 189	10,000-15,000£/ \$18,000-27,000	bought in	7
Egyptian Sculpture	Bronze head of a cat; height: 4-1/8" high; Ptolemaic period	S, London; July 5, 1982; No. 190a	1,000-1,500£/ \$1,800-2,700	bought in	5

PIECE	DESCRIPTION	SELLER	ESTIMATE	SELLING PRICE	RATE
Egyptian Sculpture	Limestone pair statue with two kneeling male figures; height: 13-5/8"; new kingdom period from Thebes	S, London; July 5, 1982; No. 101	2,000-3,000£/ \$3,600-5,400	4,400£/ \$7,700	7
Egyptian Sculpture	Basalt male bust; height: 7 1/2"; late 26th dynasty, circa 600-525 BC	S, London; July 5, 1982; No. 123	1,500-2,500£/ \$2,700-4,500	bought in	7
Egyptian Sculpture	Bronze seated male figure; height: 8 1/2"; 26th dynasty	S, London; July 5, 1982; No. 105	1,200-1,500£/ \$2,160-2,700	bought in	5
Egyptian Sculpture	Small dark gray stone male figure; height: 5-5/8"; middle kingdom	S, London; July 5, 1982; No. 149	200-300£/ \$360-450	462£/ \$808	4 very common
Egyptian Sculpture	Bronze seated figure of Huppocrates; height: 6-1/8"; 26th dynasty	S, London; July 5, 1982; No. 172	400-600£/ \$720-1,080	770£/ \$1,348	5
Egyptian Sculpture	Bronze group of Isis and Horus; height: 12-3/4"; 26th dynasty	S, London; July 5, 1982; No. 173	15,000-18,000£/ \$27,000-32,400	bought in	8 pristine
Egyptian Sculpture	Bronze figure of a cat; height: 9"; late period	S, London; July 5, 1982; No. 177	4,500-6,500£/ \$8,100-11,700	bought in	5
Egyptian Sculpture	Dark brown granite male figure seated; height: 10"; middle kingdom	S, London; July 5, 1982; No. 188	10,000-12,000£/ \$18,000-21,600	bought in	7
Egyptian Sculpture	Bronze figure of Somtous seated; height: 9 1/4"; 26th-30th dynasty (664-342 BC)	S, London; July 5, 1982; No. 189	10,000-15,000£/ \$18,000-27,000	bought in	7
Egyptian Sculpture	Bronze head of a cat; height: 4-1/8" high; Ptolemaic period	S, London; July 5, 1982; No. 190a	1,000-1,500£/ \$1,800-2,700	bought in	5

PIECE	DESCRIPTION	SELLER	ESTIMATE	SELLING PRICE	RATE
Egyptian Sculpture	Bronze figure of Somtous standing; height: 9-5/8"; 26th dynasty	S, London; July 5, 1982; No. 190b	3,000-4,000£/ \$5,400-7,200	bought in	6
Roman Sculpture	Bronze head of a woman; height: 3-3/4"; circa 2nd century AD	S, London; July 5, 1982; No. 290a	200-400£/ \$360-720	308£/ \$540	4
Greek Ceramic	Terra cotta plastic vase in the form of a siren; height: 5 1/4"; 5th century BC	S, London; July 5, 1982; No. 291	1,500-2,000£/ \$2,700-3,600	bought in	6
Greek Ceramic	Terra cotta figure of a young woman standing wearing a chiton; height: 9"; 3rd century BC	S, London; July 5, 1982; No. 296	600-800£/ \$1,080-1,440	bought in	5
Greek Ceramic	Hellenistic terra cotta figure of a young woman; height: 12 1/2"; 3rd century BC	S, London; July 5, 1982; No. 297	800-1,000£/ \$1,440-1,800	bought in	5
Greek Ceramic	Hellenistic terra cotta figure of Aphrodite standing nude; height: 10-3/8"; circa 2nd-1st century BC	S, London; July 5, 1982; No. 300	2,000-2,500£/ \$3,600-4,500	bought in	6
Greek Ceramic	Attic black figure band cup; diameter: 11-3/4"; 6th century BC	S, London; July 5, 1982; No. 307	300-500£/ \$540-900	550 £/ \$963	5
Greek Ceramic	Attic red figure Kylix by Epiktetos depicting fighting warriors; diameter: 15 1/2"; circa 500 BC	S, London; July 5, 1982; No. 311	2,000-4,000£/ \$3,600-7,200	bought in	6
Greek Ceramic	Attic red figure Kylix by the Schroeder painter depicting jumper and other athletes; diameter: 16 1/4"; 5th century BC	S, London; July 5, 1982; No. 312	6,000-8,000£/ \$10,800-14,400	bought in	6 good condition

PIECE	DESCRIPTION	SELLER	ESTIMATE	SELLING PRICE	RATE
Greek Ceramic	Attic black figure neck Amphora from the workshop of Lydos depicting swan and lotus leaves; height: 12½"; circa 500 BC	S, London; July 5, 1982; No. 314	800-1,200£/ \$1,440-2,160	bought in	5
Greek Ceramic	Attic red figure mug by the painter of Berlin 2268; decorated with nude muse dancing; height: 4"; 5th century BC	S, London; July 5, 1982; No. 316	4,000-6,000£/ \$7,200-10,800	5,500£/ \$9,625	7 unusual shape
Greek Ceramic	South Italian terra cotta hollow plastic vase depicting female head with female figure upon her; height: 18"; 3rd century BC	S, London; July 5, 1982; No. 331	2,000-3,000£/ \$3,600-5,400	bought in	6
Greek Ceramic	Attic black-glazed pottery Amphora having palmette motif; height: 13-3/8"; late 16th century BC	S, London; July 5, 1982; No. 339	400-800£/ \$750-1,450	880£/ \$1,540	5
Greek Ceramic	Attic red figure Lekythos attributed to the Phiale painter depicting figure of youth and figure of woman; height: 14"; circa 430 BC	S, London; July 5, 1982; No. 341	600-800£/ \$1,080-1,440	bought in	5
Greek Ceramic	Attic black figure neck Amphora by the Euphiletos painter depicting warrior and chariot on one side and two warriors in combat on the other; height: 16½"; 6th century BC	S, London; July 5, 1982; No. 343	12,000-16,000£/ \$21,600-28,800	16,500£/ \$28,875	7
Greek Ceramic	Attic red figure Kylix by the Bowdoin-Ieye painter depicting figure of youth; diameter: 16½"; 5th century BC	S, London; July 5, 1982; No. 351	1,500-2,000£/ \$2,700-3,600	bought in	5

PIECE	DESCRIPTION	SELLER	ESTIMATE	SELLING PRICE	RATE
Roman Sculpture	Marble head of a young satyr; height: 9"; circa 2nd century AD	S, London; July 5, 1982; No. 354	1,500-2,000£/ \$2,700-3,600	bought in	6
Roman Sculpture	Marble head of a man; height: 10½"; circa 1st century BC-1st century AD; nose broken	S, London; July 5, 1982; No. 355	2,000-3,000£/ \$3,600-5,400	bought in	6
Roman Sculpture	Large marble head of Apollo; height: 13"; circa 1st-2nd century AD	S, London; July 5, 1982; No. 358a	1,000-2,000£/ \$1,800-3,600	2,090£/ \$3,658	7
Roman Sculpture	Figure of Fortuna based on a 4th century BC original; height: 36"; circa 200 AD	S, London; July 5, 1982; No. 369	8,000-12,000£/ \$14,400-21,600	6,050£/ \$10,588	8
Roman Sculpture	Life size marble figure of a woman draped; height: 65"; circa 1st-2nd century AD	S, London; July 5, 1982; No. 370	2,000-3,000£/ \$3,600-5,400	bought in	7 no head
Greek Ceramic	Hellenistic terra cotta figure of a young woman draped; height: 10-¾"; circa 3rd century BC	S, London; July 5, 1982; No. 373	800-1,200£/ \$1,440-2,160	1,100£/ \$1,925	5
Greek Ceramic	Attic black figure Amphora from the wider circle of Exekias, one side depicting battle, another side depicting seated warrior; height: 20"; circa 540 BC	S, London; July 5, 1982; No. 383	12,000-15,000£/ \$21,600-27,000	bought in	7 good condition
Greek Ceramic	Attic red figure Kylix by the Bonn painter depicting warriors fighting on one side and a horse and rider on another; diameter: 15¼"; circa 500 BC	S, London; July 5, 1982; No. 390	10,000-15,000£/ \$18,000-27,000	18,150£/ \$31,763	8

PIECE	DESCRIPTION	SELLER	ESTIMATE	SELLING PRICE	RATE
Greek Ceramic	Attic red figure Bell Krater by the Methyse painter depicting Athena on one side and satyr on the other; height: 14-5/8"; circa 450 BC	S, London; July 5, 1982; No. 391	5,000-8,000£/ \$9,000-14,400	bought in	8
Greek Sculpture	Hellenistic marble fragment from a Hero funerary relief; 14" x 10 1/2"; late 4th century-3rd century BC	S, London; July 5, 1982; No. 399	800-1,200£/ \$1,440-2,160	3,080£/ \$5,390	6
Roman Sculpture	Small marble head of a boy; height: 8"; circa 1st century AD	S, London; July 5, 1982; No. 400	300-500£/ \$540-900	660£/ \$1,155	6
Roman Sculpture	Marble head of a young woman; height: 13-3/4"; circa 1st century AD; nose broken	S, London; July 5, 1982; No. 402	4,000-6,000£/ \$7,200-10,800	8,800£/ \$15,400	7
Roman Sculpture	Marble head of a young man; height: 9 1/4"; circa 1st century AD	S, London; July 5, 1982; No. 403	4,000-6,000£/ \$7,200-10,800	12,100£/ \$21,175	8 good condition
Greek Ceramic	Apulian fish plate with three dolphins; diameter: 8"; circa 330 BC	S, London; July 5, 1982; No. 415	600-800£/ \$1,080-1,440	bought in	5
Greek Ceramic	Footed plate painted with two large fish and one small fish; Apulian; diameter: 6 5/8"(16.3 cm); circa 4th century BC	AEG, New York; July 1982		\$2,200	5
Greek Ceramic	Footed plate painted with three fish; Paestum, Italy; diameter: 8 1/4"(21cm); circa 4th century BC	AEG, New York; July 1982		\$2,800	5
Roman Glass	Unguentarium; height: 3 3/4"; circa 1st century AD/BC	DJG, Birmingham, MI;		\$165	5
Roman Glass	Unguentarium; height: 4 1/2"; circa 1st century AD/BC	DJG, Birmingham, MI;		\$195	5

PIECE	DESCRIPTION	SELLER	ESTIMATE	SELLING PRICE	RATE
Roman Glass	Unguentarium; height: 4 3/4"; circa 1st century AD/BC	DJG, Birmingham, MI		\$175	5
Roman Glass	Unguentarium; height: 2 15/16"; circa 1st century AD/BC	DJG, Birmingham, MI		\$195	5
Roman Glass	Unguentarium; height: 5"; circa 1st century AD/BC	DJG, Birmingham, MI		\$250	5
Roman Glass	Unguentarium; height: 3 7/8"; circa 1st century AD/BC	DJG, Birmingham, MI		\$165	5
Roman Glass	Unguentarium; height: 5 3/8"; circa 1st century AD/BC	DJG, Birmingham, MI		\$200	5
Roman Glass	Balsamarium; height: 3 1/2"; circa 1st century AD/BC	DJG, Birmingham, MI		\$200	5
Roman Glass	Unguentarium; height: 4 5/16"; circa 1st century AD/BC	DJG, Birmingham, MI		\$155	5
Roman Glass	Balsamarium; height: 3 3/4"; circa 1st century AD/BC	DJG, Birmingham, MI		\$200	5
Roman Glass	Balsamarium; height: 2 1/4"; circa 1st century AD/BC	DJG, Birmingham, MI		\$185	5
Roman Glass	Unguentarium; height: 4"; circa 1st century AD/BC	DJG, Birmingham, MI		\$135	5
Roman Glass	Balsamarium; height: 2 5/8"; circa 1st century AD/BC	DJG, Birmingham, MI		\$135	5
Roman Glass	Unguentarium; height: 4 1/4"; circa 1st century AD/BC	DJG, Birmingham, MI		\$175	5



## BIBLIOGRAPHY

- Aldred, Cyril, The Development of Ancient Egyptian Art, Alec Tiranti, Inc., London, 1965
- Baines, John, Atlas of Ancient Egypt, Facts on File Publications, New York, 1980
- Beazley, J.D. & Ashmore, B., Greek Sculpture and Paintings, London, University Press, 1966
- Biers, William R., The Archaeology of Greece, Cornell University Press, 1975
- Boardman, John, Athenian Red Figure Vases, The Archaic Period, Oxford University Press, 1975
- \_\_\_\_\_, Greek Art, New York, Oxford University Press, 1964
- Bonnaffi, Edmond, Les Collectionneurs de l'Ancienne Rome, Paris, A. Dubry, 1867
- Bratakos, Petros, Systems Analyst, Modern Urban Systems Technology, Inc., President
- Braun, Barbara, "Subtle Diplomacy Solves a Custody Case", ArtNews, 81 (Summer 1982): 42-46
- Carlson, E.F., Evolution of Artistic Taste in the U.S. 1820-1920, Cambridge, England, University of Cambridge Press, 1950
- Catling, H.W., "Archaeology in Greece, 1975-1976", American Journal of Archaeology, Winter 1976; pages 330-353
- Caubet, Annie, The Louvre Catalogue of Antiquities, Paris, Editions l'Indispensable, 1978
- Collector-Investor Magazine
- Davies, D.G., "Museums and Archaeology - a lost cause?", Museum Journal, December, 1978, pages 123-125
- Duboff, Leonard, The Desk Book of Art Law, Washington, D.C., Federal Publications, Inc., 1977
- Duffy, Robert E., Art Law, McGraw-Hill, 1978
- Eisenberg, Jerome M., "Forgery and Fraud in Ancient Art", manuscript, La Jolla, California, 1970
- Engelbach, Reginald, Introduction to Egyptian Archaeology, Cairo, General Organization for Government Print Offices, 1961

- Fleming, Stuart J., Authenticity in Art: The Scientific Detection of Forgery, New York, Crane, Russack Co., Inc., 1976
- Grant, Judith, The Pillage of Art, Robert Hale, 1966
- Hanfmann, George, Roman Art, New York, W.W. Norton & Co., Inc., 1975
- Hauser, Arnold, Mannerism, New York, Alfred A. Knopf, 1965
- \_\_\_\_\_, The Social History of Art, New York, 1951
- Henle, Jane, Greek Myths, A FASE Painter's Notebook, Indiana University Press, 1973
- International Council of Museums (ICOM), Ethics of Acquisition, ICOM, Paris, 1971
- Katzander, Howard L., editor, International Art Market Tabloid
- Kent, Frank, "Icons of the Community," Monograph Number Three ASA, Washington, D.C., January 1, 1960
- Lacy, A.D., Greek Pottery in the Bronze Age, Faber, 1969
- Lehmann-Haupt, Hellmut, Art Under a Dictatorship, New York, Oxford University Press, 1954
- Lloyd, Seton, The Art of the Ancient Near East, Oxford University Press, 1961
- MacBride, Dexter D., editor, The Bibliography of Appraisal Literature, Washington, D.C., American Society of Appraisers, 1974
- Melas, Evi, Temples and Sanctuaries of Greece, London, Thames and Hudson, 1973
- Meyer, Karl E., The Art Museum, New York, William Morris & Co., 1979
- Montreal, Luis, "Problems and Possibilities in Recovering Dispersed Cultural Heritage," Museum, March 1980
- Petrie, Sir William Matthew Flinders, Egyptian Collections at the University College, London, 1965
- Phillips, John, editor, The British Museum Catalogue of Greek and Roman Antiquities, London, Phaidon Press, 1973
- Reitlinger, Gerat, The Economics of Taste, London, Berry & Rockleff, 1973
- Rheims, Maurice, The Strange Life of Objects, New York, Atheneum Publications, 1961
- Richter, Gisela, A Handbook of Greek Art, Cambridge University Press, 1974
- Robertson, D.S., Greek & Roman Architecture, Cambridge University Press, 1969

- Rollet-Andrienne, Louis-Jacques, "Precedents," Museum, March 1982
- St. Louis Post-Dispatch, February 1973, Section B, p.3
- Sales Catalogues and Summaries from Sotheby's and Christies Auction Houses.
- Savage, George, Forgeries, Fakes and Reproductions, London, Barrie and Rockliff, 1963
- Schreiber, Lady Charlotte Elizabeth Guest, Lady Charlotte Schreiber's Journals, London, John Lane, 1911
- Smith, William Stevenson, The Art and Architecture of Ancient Egypt, New York, Penguin Books, 1981
- Sotheby-Parke-Bernet, Art at Auction, 1920-1921, New York, Viking Press, 1921
- Spitzer, Frederic, La Collection Spitzer, Macon Protat Freres, 1980
- UNESCO, "Convention of the Means of Prohibiting and Preventing the Illicit Import, Export, and Transfer of Ownership of Cultural Property," Paris, 1970
- Vainowski, Bob, King Tut's Tomb and the Curse, C.S. Productions, 1979
- Webster, T.B.L., Hellenistic Art, Art of the World Series, Methuen, 1966
- Weinbacher, Dr. Hans, Art at Auction
- Wheaton, Henry, Elements of International Law, Volume I, Leipzig, F.A. Brockhaus, 1852

## KEY TO ABBREVIATIONS

1. JLM Joel L. Matter & Company  
Encino, California
2. RAG Royal Atheneum Gallery  
New York, New York
3. AEG Andre Emmerich Gallery  
New York, New York
4. SPB Sotheby Parke Bernet  
New York, New York
5. S Sotheby's  
London, England
6. DJG Donna Jacobs Gallery  
Birmingham, Michigan

## BIBLIOGRAPHY

- Aldred, Cyril, The Development of Ancient Egyptian Art, Alec Tiranti, Inc., London, 1965
- Baines, John, Atlas of Ancient Egypt, Facts on File Publications, New York, 1980
- Beazley, J.D. & Ashmore, B., Greek Sculpture and Paintings, London, University Press, 1966
- Biers, William R., The Archaeology of Greece, Cornell University Press, 1975
- Boardman, John, Athenian Red Figure Vases, The Archaic Period, Oxford University Press, 1975
- \_\_\_\_\_, Greek Art, New York, Oxford University Press, 1964
- Bonnaiffi, Edmond, Les Collectionneurs de l'Ancienne Rome, Paris, A. Dubry, 1867
- Bratakos, Petros, Systems Analyst, Modern Urban Systems Technology, Inc., President
- Braun, Barbara, "Subtle Diplomacy Solves a Custody Case", ArtNews, 81 (Summer 1982): 42-46
- Carlson, E.F., Evolution of Artistic Taste in the U.S. 1820-1920, Cambridge, England, University of Cambridge Press, 1950
- Catling, H.W., "Archaeology in Greece, 1975-1976", American Journal of Archaeology, Winter 1976; pages 330-353
- Caubet, Annie, The Louvre Catalogue of Antiquities, Paris, Editions l'Indispensable, 1978
- Collector-Investor Magazine
- Davies, D.G., "Museums and Archaeology - a lost cause?", Museum Journal, December, 1978, pages 123-125
- Duboff, Leonard, The Desk Book of Art Law, Washington, D.C., Federal Publications, Inc., 1977
- Duffy, Robert E., Art Law, McGraw-Hill, 1978
- Eisenberg, Jerome M., "Forgery and Fraud in Ancient Art", manuscript, La Jolla, California, 1970
- Engelbach, Reginald, Introduction to Egyptian Archaeology, Cairo, General Organization for Government Print Offices, 1961

- Fleming, Stuart J., Authenticity in Art: The Scientific Detection of Forgery, New York, Crane, Russack Co., Inc., 1976
- Grant, Judith, The Pillage of Art, Robert Hale, 1966
- Hanfmann, George, Roman Art, New York, W.W. Norton & Co., Inc., 1975
- Hauser, Arnold, Mannerism, New York, Alfred A. Knopf, 1965
- \_\_\_\_\_, The Social History of Art, New York, 1951
- Henle, Jane, Greek Myths, A FASE Painter's Notebook, Indiana University Press, 1973
- International Council of Museums (ICOM), Ethics of Acquisition, ICOM, Paris, 1971
- Katzander, Howard L., editor, International Art Market Tabloid
- Kent, Frank, "Icons of the Community," Monograph Number Three ASA, Washington, D.C., January 1, 1960
- Lacy, A.D., Greek Pottery in the Bronze Age, Faber, 1969
- Lehmann-Haupt, Hellmut, Art Under a Dictatorship, New York, Oxford University Press, 1954
- Lloyd, Seton, The Art of the Ancient Near East, Oxford University Press, 1961
- MacBride, Dexter D., editor, The Bibliography of Appraisal Literature, Washington, D.C., American Society of Appraisers, 1974
- Melas, Evi, Temples and Sanctuaries of Greece, London, Thames and Hudson, 1973
- Meyer, Karl E., The Art Museum, New York, William Morris & Co., 1979
- Montreal, Luis, "Problems and Possibilities in Recovering Dispersed Cultural Heritage," Museum, March 1980
- Petrie, Sir William Matthew Flinders, Egyptian Collections at the University College, London, 1965
- Phillips, John, editor, The British Museum Catalogue of Greek and Roman Antiquities, London, Phaidon Press, 1973
- Reitlinger, Gerat, The Economics of Taste, London, Berry & Rockleff, 1973
- Rheims, Maurice, The Strange Life of Objects, New York, Atheneum Publications, 1961
- Richter, Gisela, A Handbook of Greek Art, Cambridge University Press, 1974
- Robertson, D.S., Greek & Roman Architecture, Cambridge University Press, 1969

- Rollet-Andrienne, Louis-Jacques, "Precedents," Museum, March 1982
- St. Louis Post-Dispatch, February 1973, Section B, p.3
- Sales Catalogues and Summaries from Sotheby's and Christies Auction Houses.
- Savage, George, Forgeries, Fakes and Reproductions, London, Barrie and Rockliff, 1963
- Schreiber, Lady Charlotte Elizabeth Guest, Lady Charlotte Schreiber's Journals, London, John Lane, 1911
- Smith, William Stevenson, The Art and Architecture of Ancient Egypt, New York, Penguin Books, 1981
- Sotheby-Parke-Bernet, Art at Auction, 1920-1921, New York, Viking Press, 1921
- Spitzer, Frederic, La Collection Spitzer, Macon Protat Freres, 1980
- UNESCO, "Convention of the Means of Prohibiting and Preventing the Illicit Import, Export, and Transfer of Ownership of Cultural Property," Paris, 1970
- Vainowski, Bob, King Tut's Tomb and the Curse, C.S. Productions, 1979
- Webster, T.B.L., Hellenistic Art, Art of the World Series, Methuen, 1966
- Weinbacher, Dr. Hans, Art at Auction
- Wheaton, Henry, Elements of International Law, Volume I, Leipzig, F.A. Brockhaus, 1852