



15TH ANNUAL STUDENT FASHION SHOW

DESIGN
DISTRICT

LINDENWOOD

LINDENWOOD UNIVERSITY ST. CHARLES, MISSOURI

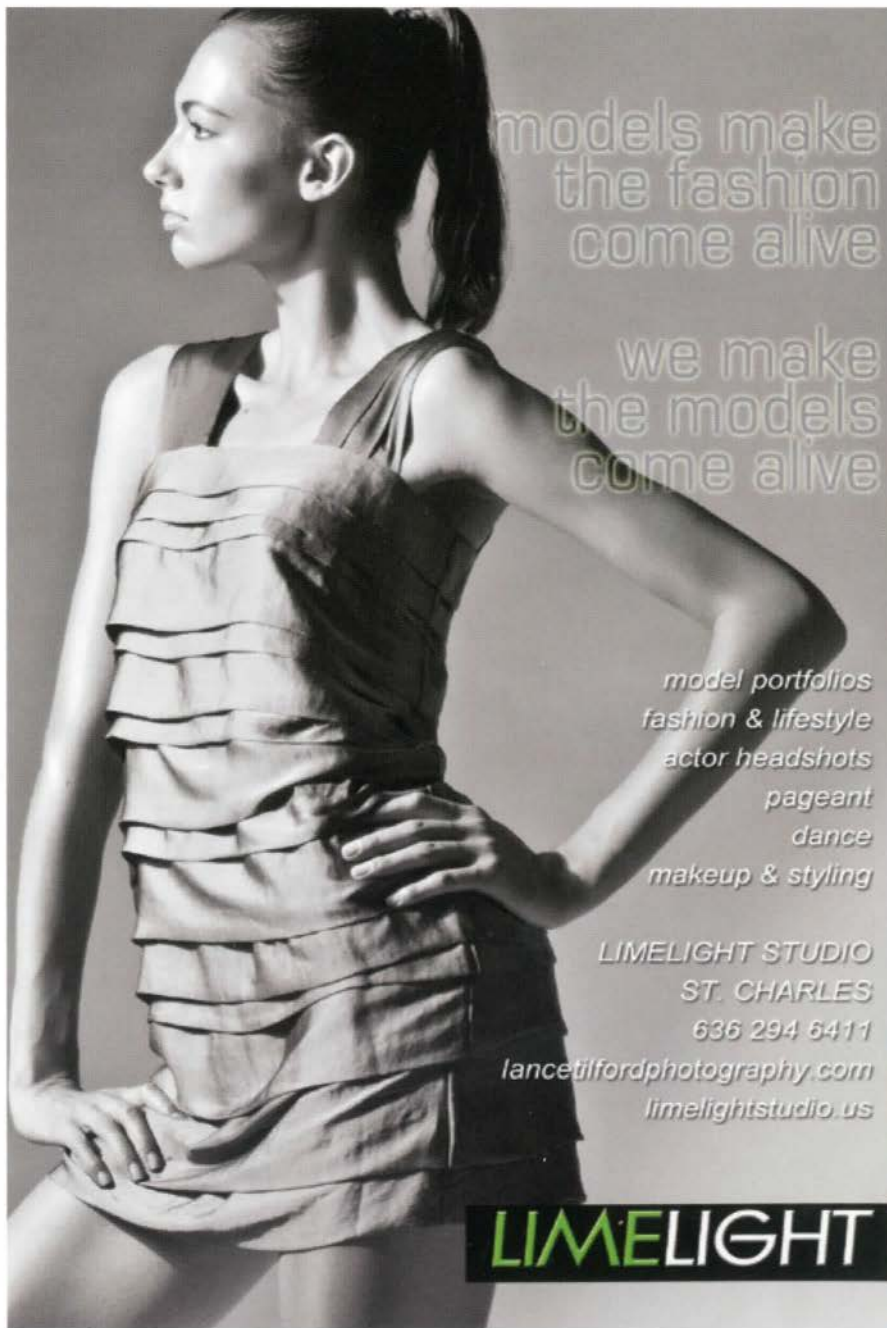

models make
the fashion
come alive

we make
the models
come alive

*model portfolios
fashion & lifestyle
actor headshots
pageant
dance
makeup & styling*

LIMELIGHT STUDIO
ST. CHARLES
636 294 6411

*lancetilfordphotography.com
limelightstudio.us*

LIMELIGHT



Design District

Lindenwood University Student Fashion Show

Commentators

Laura Kathleen Planck – Fashion Designer, *Project Runway* Season 9, top 5 finalists
Master of Ceremonies

Joe Alsobrook – Dean of Fine and Performing Arts, Lindenwood University

Florence Dewan – Fashion Design Program Chair, Lindenwood University

Ameli Skoglund – President, Lindenwood Fashion Club, Lindenwood University

Jury

Debra Bass – Fashion Editor, *St. Louis Post-Dispatch*

Lori Culter – Owner, True Measure

Suzzane Scott Lay – Designer/ Owner at Suzzane Lay

Laura Kathleen Planck – Fashion Designer, *Project Runway* Season 9

Dwight Carter – Owner, Rock Uniform PR

Greta Hale – Style and Trend, Brown Shoe

Construction Judges

Kristy Lee – Owner, K.Lee Productions, LLC.

Denise Schindler – FACS Educator, Ritenour High School

Paula Wepprich

Chris Dodson

LINDENWOOD

LINDENWOOD UNIVERSITY

ST. CHARLES, MISSOURI

The Show

Line-up

Art to Wear: Transparence

Swimwear

Production Design: Marchesa, Alexander McQueen, and Elie Saab

Mini Collections

Senior and Graduate Collections

Mini Collections

Kate Elbert – T.C.E

Wendy Stamps – Mirage

Altjin Batkhuu – Stanza

Jessica Meyer – Hollywood

Ameli Skoglund – Fidelity

Elizabeth Turner – GAMMA RAY

Abaya Dake – Esteem

Graduate Collections

Kasey McCormick – Pirouette

Elizabeth Turner – Prêt-a-Couture

Wendy Stamps – S.O.S.N

Lisa Leite – Pattern Puzzle

Senior Collections

Jessica Affspring – Bright is the New Black

Camille Gibson – Amber Lights

Dorothy Doll – Pieceofcake

Alex Taylor – Plaid Denim

Angela Renee – Artfully Beautiful

Lauren Alfaro – Penchant for Pretty

Deerra Williams – A Tribute to Shawn C. Williams: Re Constructed De Struction

Altjin Batkhuu – Empire

Kristie Keys – Kristie Kay

Angela Grana – Noir

Abaya Dake – Sankofa

Graduate Bios



Kasey McCormick
Pirouette

This collection, *Pirouette*, is a reflection of how ballet introduced her to love the arts. Inspired by the grace and poise exuded by dancers, particularly Degas' famous "Ballerinas," Kasey based the romantic and feminine style of her collection on her favorite ballet, "Swan Lake". Her path to falling in love with design and styling was not traditional, but a love that will last a lifetime. Kasey was able to supplement her knowledge of design through her design internship with Amy Johnson at KayOss Designs, receiving great encouragement during her time there. Kasey aspires to work as a stylist, ideally in the magazine industry, where she recently interned for *Glamour* magazine in New York City. Kasey would like to thank her parents for supporting her in following her dreams.



Elizabeth Turner
Prêt-a-Couture

I came to LU to pursue an MFA in fashion design after completing my BS in fashion merchandising at SEMO. *Prêt-a-Couture*, my senior thesis, is a fusion of my retail background and my search for an artistic identity. Inspired by historic designer Madeline Vionnet, I created couture-influenced, ready-to-wear pieces which harken to art deco sensibilities. I hope to complete my internship this summer and work in the corporate arena after the completion of my degree this December. For the rest of my life, I want to pursue design with "an inner purity and an outward splendor" (Abbot Suger). Follow my evolution as a designer and stylist at www.elizabethturnerstyle.com. Thank you to my brilliant husband Matt and both of our families.



Wendy Stamps
S.O.S.N.

From a young age, Wendy was drawn to the world of fashion. Her parents often found her beneath the covers with a flashlight while she imagined designing dresses for her Barbies. This fascination with clothing and a desire to create beautiful garments manifested itself into an MFA in fashion design, which will be completed in May 2012. Her graduate collection, *S.O.S.N.*, exemplifies Wendy's true passion – bridal wear. *S.O.S.N.* is an abbreviation of "something old, something new," the perfect combination of classic silhouettes with modern flairs for wedding gowns. Wendy hopes to start her own bridal or children's wear line in the near future. She would like to thank her friends and family for supporting her dreams and their constant encouragement.



Lisa Leite
Pattern Puzzle

Consistently delighting audiences, Lisa once again adds her distinctive talent to the runway. Lisa's latest collection, *Pattern Puzzle*, perfectly combines clean shapes and structured silhouettes with voluminous aspects. *Pattern Puzzle* is a well edited collection featuring geometric shapes cleverly combined into a beautiful puzzle. She diverges from her preferred draping techniques to create more tailored looks while maintaining her exquisite, diverse style. Lisa will graduate with her MFA in Summer 2012 and plans to continue in fashion by designing for a boutique in Brazil.

Senior Bios



Jessica Affsprung
Bright is the New Black

When you walk out your door, the world becomes your audience. The streetlights suspended from above guide you down the runway. The flashbulbs are going off, blinker by blinker as you walk down the street. The beat of your heels mimics the one being projected through your headphones. Your thick designer sunglasses morph into blinders, delaying the daylight of reality. Anything other than that cup of coffee in your near future seems to fade away. Slow sipping leads to reminiscing, while staring at the red lipstick kiss on the side of your coffee mug... You're suddenly thinking of his voice and how delicious he smelled... You just had to slide him the napkin with your number signed in that same red lipstick. The memory makes you smile as you take another sip of your coffee.



Camille Gibson
-Amber Lights-

Camille has always had a passion for the field of fashion. From the shows she watched to every flip of a magazine, she viewed effortless creations that the celebrities and city dwellers wore. Camille began to pursue her education in fashion design after spending some time in Korea. Delicate blouses, dresses, fitted jeans, layered tights, and classic leather footwear inspired her to combine the Korean style with her own. Camille loves to play around with textures and colors by combining the two in a sophisticated way. Amber Lights is the road to internal strength.



Dorothy Doll
Pieceofcake

Gaining enthusiasm for fashion and style at a young age, Dorothy has always dreamt of obtaining a career pertaining to both. Expressing herself through her clothing day to day, she finds that it is the love of standing out which matters to her most. Her greatest goal is not to be one with the crowd, but to stand apart from it. As she gains inspiration from her own style and from fashion blogs, the trendy and comfort aspect becomes apparent in Dorothy's collection, *Pieceofcake*. This collection illustrates unique simplicity with a wow factor, and turning a head or two becomes an effortless reward.



Alex Taylor
Plaid Denim

Alex initially attended school in Indianapolis, Ind, where he sought a degree in general art education. However, he soon recognized his appreciation for fashion, and in 2010 he chose to pursue this as his major. Within the last two years, he has grown as a designer and experimented with a number of fabrics and styles. His senior collection, incorporating classic plaid, denim and leather, displays a polished yet lively fashion. While the work is inspired by Alexander McQueen and Jean Paul Gaultier, it also embodies the relationships and experiences Alex has shared with his creative colleagues. Upon graduation, Alex plans to travel the world, find inspiration in the artistic pursuits of others, and perfect his craft and style.

Senior Bios



Angela Renee
Artfully Beautiful

Angela has lent her proficiency to the fashion community for many years, serving in a wide array of many capacities. Such pursuits include producing, modeling and being the sole cosmetic artist for many fashion events and venues. In spring of 2009 Angela Renee enrolled at the prestigious Lindenwood University of St. Charles, Mo., joining its fashion program and garnering many honors.

Angela's immense aptitude and raw eye for fashion make both the designer and her collections a matchless and unique asset to fashion and art for both eras and cultures to come.



Lauren Alfaro
Penchant for Pretty

Lauren Alfaro is excited to showcase her interpretation of the upcoming trends for spring 2013 in the collection Penchant for Pretty. Her inspiration for the collection was drawn from her love for all things pretty and girly. She wanted to create a collection that would be fun and easy to wear. The color palate was influenced by the glimmer of oceanic colors. Lauren has completed an internship with DIYStyle and is currently interning for Vogue Footwear. She is excited to graduate and pursue her love of design in the real world. Lauren is most thankful for all the love and encouragement from her husband Jon, family, and friends.



Deerra Williams

A Tribute to Shawn C. Williams: Re Constructed De Struction

Deerra Williams was born in Manila, Philippines, and raised in St. Louis, Mo. Deerra's brother, Shawn C. Williams, who attended Lindenwood University as well, taught her how to sew with their family sewing machine. The siblings started Eyekon Klothng Co.--an urban lifestyle brand with Shawn at the head. Shawn passed away in September of 2008. Deerra strives to live out his motto "love, laugh, and live your life," and to keep his legacy alive. Inspired by her brother's line, in 2007, Deerra created her line called Deerra Nickkol as a reflection of her faith and free spirit. Deerra's designs have graced Memphis, St. Charles and L.A. Fashion Weeks. In 2011, in the memory of her brother, she opened a clothing boutique, Fashion House, in the University City Loop.



Altjin Batkhoo

Empire

Altjin Batkhoo, is from the capital city of Ulaanbaatar, Mongolia. Altjin came to the United States in 2006. Her design aesthetic is geared toward avant-garde and couture garments which have intricate details and structures. Her inspirational designers are John Galliano and Alexander McQueen, yet also finds inspiration from progressive trance, house, and dubstep music. Altjin's senior collection titled Empire represents cohesive avant-garde couture dresses with unique combinations of aggressive tailoring. The name "Empire" relates to the history of a Mongolian king who ruled half of the world in the 12th century. This is an important time in her life at Lindenwood University to represent both herself and her nationality.

Senior Bios



Kristie Ann Keys
Kristie Kay

Born and raised in St. Louis, Kristie has always been supported by her friends and family to follow her dreams as a fashion designer. She is now starting her own company and will soon graduate from Lindenwood with a BFA in Fashion design with an eventual MA in business administration. Her inspiration to design an evening wear/couture collection was derived from her internship in New York with couture designer German Valdivia. Her collection "Kristie Kay" is designed to enhance the elegance and beauty that all women possess. For further information, she can be contacted at KristieKeys@gmail.com.



Angela Grana
Noir

At the age of 13, Angela began sewing, which then inspired her to design garments she herself wanted to wear. She moved on to create costumes for Renaissance fairies, pirate festivals, and a Halloween party, realizing costuming was her true passion, whether it be true to history or just for fun. Her aesthetic is darker than most, sometimes combined with romantic aspects, but always with edge. Her senior collection embodies this perfectly, merging her love of hardware and corsetry. After obtaining a BFA in fashion design with a minor in retail merchandising, Angela may continue to receive an MFA in costume design. She hopes to work in theatre one day as a designer and seamstress.



Abaya Dake
Sankofa

Abaya was born in Ghana. Growing up, he had a keen interest in the sciences and arts. After high school, he enrolled in a local fashion school in his native country where he learned the basics of fashion. In pursuit of higher education, he moved to the United States to pursue a degree in fashion design.

Abaya's upbringing from a country deeply rooted in the arts for traditional rituals amplifies his sense of uniqueness. Sankofa, meaning going back to your roots, is a blend of African and Western fabrics into timeless evening pieces. This collection portrays Abaya's experiences in both worlds and relates to their harmonious nature, which has grown to make him a better person and a stronger designer.

Special Thanks

Sponsors

Steve Jeffery, Babylock USA

Michael Guccione, American Sewing Machine

Grace Wang, PGM Dress Forms

Andy Wolff, Artistic Fabrics

Amy Jackman, Jackman's Fabrics

The Lindenwood University Fashion Club

Models

West Model & Talent Management

Photography

Mike Kastler – Kastler Photography

Videography

Alex Peterson

Lighting

Lindenwood Theater Department

Music

Jessica Meyer

Hair and Make-up

Cary O'Brien – Hair Styling Director, Hair styling provided by the Cary O'Brien Design
and Color Spa Team

Program Cover

Julien Rossignol, Photography

Abaya Dake, Dress

Chandra Wood and Grace Pettit, Program design

Caitlin Bigham, Model

Jessica Williams, Hair and Make-up

Lindenwood University Fashion Club

Ameli Skoglund, President

Lisa Leite, Vice President

Jessica Meyer, Media Director

Rachel Lawshe, Treasurer

Alexis Eikerenkoetter, PR Director

Lindenwood University Faculty

Joe Alsobrook, Dean of Fine and Performing Arts

Florence Dewan, Fashion Design Program Chair

Katrina Bennett, Fashion Design Assistant Professor

Kristy Lee, Fashion Design Adjunct Professor

Darren Collier, Professor, Department of Graphic Design

Suzanne Sakahara, Fine Arts Department

Tim Poertner, Theater Department

Peter Bezemes, Executive Director, J. Scheidegger Center for the Arts



Vogue's

VOGUEFOOTWEAR.COM



Vogue Footwear is a division of Elan Polo International. Visit elanpolo.com for internship and employment information.

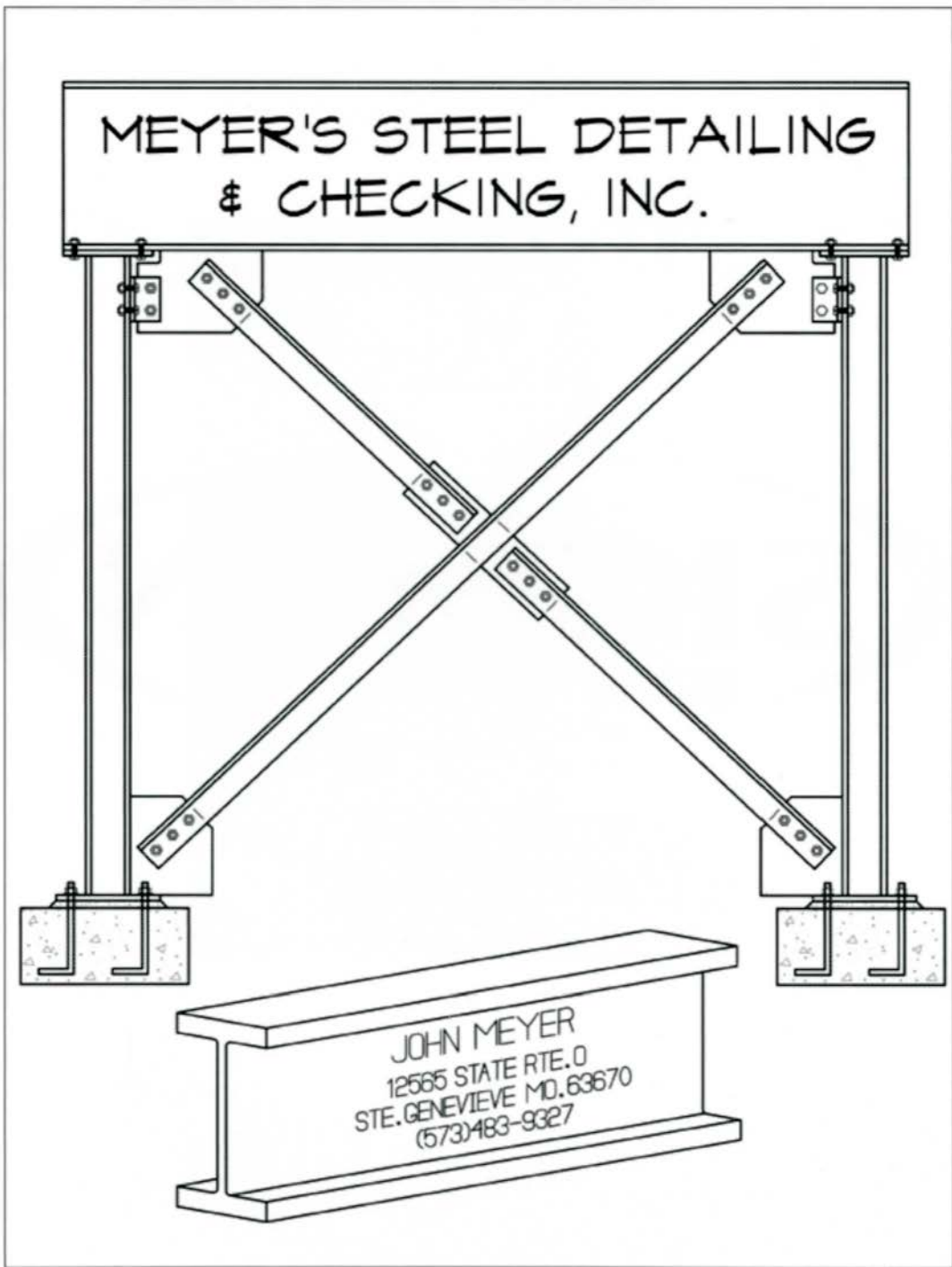



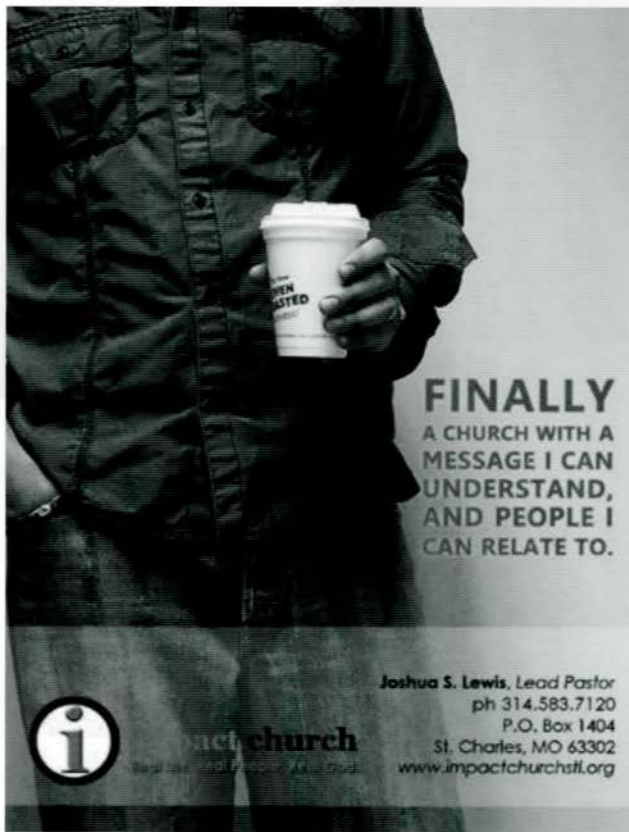



FINALLY
A CHURCH WITH A
MESSAGE I CAN
UNDERSTAND,
AND PEOPLE I
CAN RELATE TO.

Joshua S. Lewis, Lead Pastor
ph 314.583.7120
P.O. Box 1404
St. Charles, MO 63302
www.impactchurchstl.org

 **impact church**
New Life • 2013 • Mission • Jesus • God

KRISTEN'S HAIR STUDIO 17



618-254-1717
17 E. Ferguson Ave.
Wood River, IL 62095

Tues 11:00am - 7:00pm
Wed-Fri 9:00am - 5:00pm
Sat 9:00am - 2:00pm
Other Hours By Appointment

Brittany

We are so proud of you and for all of your hard work this past year. Keep on pushing for excellence. "It's not the will to win that matters - everyone has that. It's the will to prepare to win that matters." Bear Bryant

Love, Dad, Bianca and Madtoid

Your source for
European footwear
and accessories.

BRONX diba
SHOES

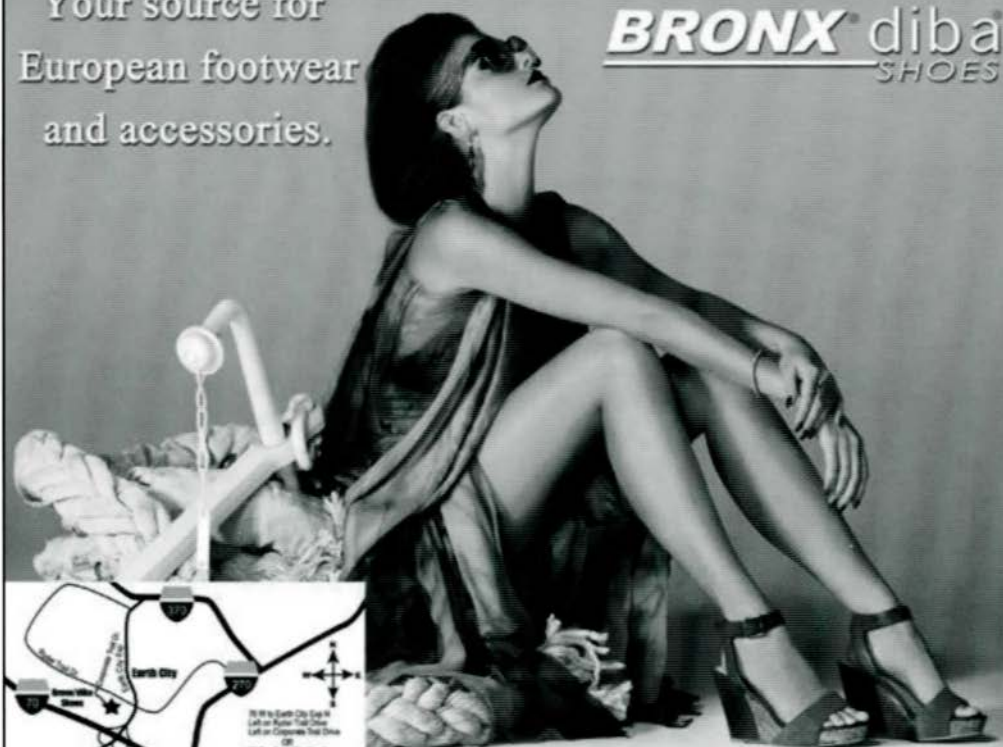

90 W. Earth City Loop W
Left on North Trail Drive
Left on Corporate Trail Drive
Rt
90 W. Earth City Loop W
Left on North Trail Drive
Left on Corporate Trail Drive

3630 Corporate Trail Dr. Earth City, MO 63045 314.373.1280
www.demandshoes.com M-F 8-6 Sat. 11-4





CARY O'BRIEN'S

DESIGN & COLOR • SPA

2107 Zumbahl Rd

St. Charles, MO 63303

636.947.1027

SOUTHWEST PUMPS & FILTERS, INC.
• Industrial Pumps & Filter Equipment -
Air, Electrical, and Engine Driven

www.southwestpumpsandfilters.com
417-868-8109

Toll Free Dial "1" & Then 888-209-3780

Lisa F. Heppermann

LH Designs

800 Castle Pines Dr.
Ballwin, MO 63021
(636) 288-7076
lisahdesigns@hotmail.com

Commercial &
Residential Design



D & W PROPERTY

HAROLD DIGGS
Co-Owner



Rental Property
Paragould, AR 72450
(870)-476-0257

Diggs Property
Quality Rental Property

Harold & Nan Diggs
Co-Owners



Diggs Property

Paragould, AR 72450
(870) 476-0257
(870)-476-7080
nbdiggs@yahoo.com

OLD MONROE

OMLC

LUMBER & RENTAL

1380 Meier Rd Old Monroe

636-661-5287

7 AM-6 PM Mon-Fri 8 AM-2 PM Sat

WWW.OMLUMBER.COM

GOOD LUCK!

FASION DESIGNERS



IN FOCUS
MARKETING, LLC.



The focus of the fashion design program is to provide education in the field of art, design, production and marketing for the apparel industry.

Degrees offered: Bachelor of Arts/ Fine Arts
Masters of Arts/ Fine Arts

For more information contact:
Florence Dewan
Fdewan@lindenwood.edu

