

LUMINOUS
a spectrum of style



SPRING
FASHION SHOW

LINDENWOOD



J. SCHEIDEGGER
CENTER FOR THE ARTS

**Enroll in one of
our continuing
education programs:**

**Dance (Hip Hop, Video
Choreography, Club ei for
kids), Drama, Voice, Video,
Photoshop, Web Design,
Songwriting, and DJ Classes**

We also offer:

**ENTERTAINMENT & MEDIA BUSINESS
WITH MANAGEMENT**

**RECORDING ENGINEERING &
PRODUCING WITH MANAGEMENT**



To learn more, visit our website at www.eibynelly.com
or call 888-841-3602 and make an appointment today!

800 N. 3rd. Street, St. Louis, MO 63102

**VATTEROTT COLLEGE
EXTREME INSTITUTE**
BY NELLY - ST. LOUIS

LUMINOUS

a spectrum of style

Lindenwood University 16th Annual Student Fashion Show

Line Up

Art-to-Wear; *Resilience*

Swim Wear

Couture; *Giambattista, Stephanie Rolland, Zuhair Murad and Valentino*

Mini Collection

Senior Collection and Garments

Graduate Collection and Garments

The Show

Mini Collections

Alexis Cook
Uptown Glam

Isaiah Jenkins
Euphoria

Senior Collections and Garments

Cassie Creech
Mini Collection *Leather and Lace*
Senior Collection *Country Chic*

Damika Day
Mini Collection *Marquis*
Senior Collection *Darlin*

Natalie Decker
Mini Collection *Giambattista*
Senior Collection *Ka'i*

Penny Duncan
Mini Collection *Who, Me???*
Senior Collection *Case Closed*

Alexis Eikerenkoetter
Mini Collection *Honey Bee*
Senior Collection *The Black and White Story*

Shanay Haynes
Mini Collection *Be True, Be You*
Senior Collection *Love Me, Hate Me*

Alison Hayworth
Mini Collection *Falling into Place*
Senior Collection *Things to Come*

Dainel Jolvette
Senior Collection *OBSERVE*

Rachel Lawshe
Senior Collection *Follow Suit*

Haley McCulloch

Mini Collection *Snake Charmer*

Senior Collection *California Dream (Slice)*

Jessica Meyer

Senior Collection *Shine by Reflection*

Tiffany Rench

Mini Collection *Flowers in the Afternoon*

Senior Collection *Maxine*

Devinne Walters

Mini Collection *Sister of Battle*

Senior Collection *Sparklestar*

Morgan Wuch

Mini Collection *Street Chic*

Senior Collection *Bohemian Flair*

Graduate Collections

Amra Alihodzic

Couture Gown *Zuhair Murad*

Graduate Collection *Homage*

Altjin Batkhuu

Couture Gown *Zuhair Murad*

Graduate Collection *Hole*

Seniors

Cassie Creech



Mini Collection *Leather and Lace*
Senior Collection *Country Chic*

When I was eleven, I asked my mom to teach me how to sew. I was inspired by my great grandma, who could whip up an outfit for one of her grandchildren in a day without using a pattern. It amazed me what she was able to do, and I wanted to be just like her. Soon after, I developed a love for fashion too, so it wasn't much of a decision to know that I wanted to pursue a career in it. A lot of my designs are based from the 1940s. My two idols are Lucille Ball and Audrey Hepburn, and they have been my inspiration throughout my creating process.

Damika Day

Mini Collection *Marquis*
Senior Collection *Darlin*

There is so much to be said about fashion design extraordinaire Damika Day. She developed her sewing as an art at just the tender age of 13, and continued to grow to love fashion through performance arts schools. Day began her journey an entrepreneur and established Dakaria Clothing CO in 2005. In 2006, she enrolled part-time in the Fashion Design Program at Lindenwood University, after achieving an associate's degree from SLCC. Day's designs normally range from dress casual to elegant after-five wear, garments that can be worn in a working environment or reserved for your formal dinner engagement. Day is sure to remain active in her passion and is appreciative of opportunities that would allow her experience in the fashion industry.



Natalie Decker



Mini Collection *Giambattista*
Senior Collection *Ka'i*

Listen. Feel the ground beneath you. Dance to the beat of the wind. Everything is precious, and it's important that we take care of it. Everything has a spirit, even these clothes. Let them inspire you, to help you be in tune with life. Know that you are connected to everything. Natalie Decker presents her collection, Kai (Navajo for Willow). Inspired by the ideas of Native American spirituality, using a well-balanced mix of leather and colorful feathers, Natalie uses her collection to remind everyone to appreciate the small things, we are all insignificant but important.

Penny Duncan

Mini Collection *Who Me???*
Senior Collection *Case Closed*

Penny Cortese Henley was born November 19 1984, to Estella Henley and William Anderson. Driven by a passion of creativity, she was always active in transforming and making things into beautiful art. Later, after dancing on a Christian tour, her passion for fashion became stronger, which lead her to attend Lindenwood University in 2008. In 2011, she became Mrs. Penny C. Duncan by marrying her husband and wonderful support system Delontate T. Duncan. She knew that starting this new journey while married and graduating would be scary and exciting, but she couldn't wait to start her own journey. She enjoys stepping out of the box with both Mini and Senior Collections and will continue with special support from friends and family.



Seniors

Alexis Eikerenkoetter



Mini Collection *Honey Bee*

Senior Collection *Evan: The Black and White Story*

You wanna rumble with the Bee, huh? Queen of my own design and style, I live life to the fullest. Spicy but sweet; that is the story of my life. I've always stood up, because the only way to be seen is to speak out. If you feel it, say it. If you look me in the eye, I don't have any worries. It's a craze; everyone will love it. Feel like a million bucks, be spontaneous, tickle your fancy, and look stunning. That's what I believe: If you like it, rock it. "Evan: The Black and White Story" is dedicated to my Uncle Evan, who passed away. To you, uncle, "What's UP?" Alexis OUT.

Shanay Haynes

Mini Collection *Be true, Be You*

Senior Collection *Love me, Hate me*

Shanay was born and raised in St. Louis, and at a young age she had a passion for fashion and photography, but it was when she reached college that she knew which one she wanted to do. Fashion became a way for her to express herself, stand out, be heard, and be proud of who she is. Her greatest goal is to have her son be proud of her and stand out from the crowd. The collection, Love me Hate me, came from her own style, expressing oneself and not caring what others may say. Some may like it; others may not; it's about being happy in the clothes that you have on.



Alison Hayworth



Mini Collection *Falling into Place*
Senior Collection *Things to Come*

Alison Hayworth is a senior at Lindenwood University pursuing a B.F.A. in fashion design and a minor in business administration. Alison's work was shown in LU's 2012 fashion show (where she won several awards) and at 2012 St. Charles Fashion Week. Alison maintains a portfolio website that can be viewed at www.whiznagoos.com. Her mini collection "Falling into Place" tells the story of her summer as she tried to find balance between lives in two places -- back at home and at school in St. Charles. Her senior collection "Things to Come" was inspired by the costumes of several characters in *Star Trek Voyager* and reflects a journey in search of adventure, life, and beauty in the things to come.

Daniel Jolvette

Senior Collection *OBSERVE*

Designing has always been prevalent in my life. In high school I use to design and draw on my tardy slips. Nothing has changed except for the fact that in college they no longer hand out tardy slips. My inspiration comes from mainly music. My aesthetic is simple with a hint of sexy. Interesting shapes and well-tailored garments are my favorite. After graduation, I hope to get out of Dodge and see the world. One day, I hope to become a successful stylist. If anyone wants to hire me, please contact my agent. I would like to thank my family and friends for always supporting me. I would thank all of my friends by name, but both of you know who you are.



Seniors

Rachel Lawshe



Senior Collection Follow Suit

From the moment I realized that glitter and a glue stick could make my plain white Keds red carpet-worthy, I had a passion for crafts and colors of all kinds. Designing quickly became an outlet for me, and I have never looked back. The concept behind my collection is the combination of elegance and trend. My studies in Florence, Italy, provided a jump-start to my inspiration as I learned how fabrics are woven together, allowing for incredible patterns and textures to be created within a single piece. My fascination with men's neck ties stemmed from the unique fabrics and patterns that make the tie so eye-catching. The goal of my collection is to take everyday pieces and manipulate them into the unexpected.

Haley McCulloch

Mini Collection Snake Charmer
Senior Collection California Dream(slice)

Haley presents this collection with a distinct taste of color and her own personal take on the West Coast style in fashion. Through her internship with Los Angeles-based designer, Haley was able to put her own unique fashion for color and personal aesthetic into a collection that embodies a fun, free, uninhibited feeling of the California lifestyle. Haley plans to further her career in Los Angeles after school, with the plan to someday use her drive, motivation and distinct eye to design for a major brand, with the dream of one day designing her own personal line.



Jessica Meyer



Senior Collection *Shine by Reflection*

Jessica is inspired by the memories of those close to her. "Shine by Reflection" was inspired by her uncle, who died in March of 2009 from ALS. The ALS is represented in the collection by the coral, and the interlocking colors of the fabric demonstrate the strong bonds she shares with her family. Jessica will graduate with a BFA in fashion design and a minor in retail merchandising this May and will continue her studies in fashion by pursuing a Master of Fine Arts in fashion design from Lindenwood University this fall. Jessica would like to thank her friends and family, especially her parents, for all of their continued support in following her dreams.

Tiffany Rench

Mini Collection *Flowers in the Afternoon* Senior Collection *Maxine*

Ever since I can remember, I have loved fashion. I used to cut up my Barbie's clothes, and then some of my own later, to make them different. My grandmother, Robbie Maxine Wilson, passed away at the beginning of last year. Since then, she has served as the inspiration for most of my designs. She was a well-dressed woman who did not feel complete without accessories, especially earrings. Though she didn't make much money, she would bargain shop and still manage to be elegantly dressed on a day-to-day basis. My senior collection is a tribute to her. I want to bring her elegant, but dated, style together with current trends. I love you, Grandma.



Seniors

Devinne Walters



Mini Collection *Sisters of Battle*
Senior Collection *Sparklestar*

Allow Devinne Walters to take you into deep space, past the solar system, to a second Earth made of love. Lock eyes with these alien girls who reflect all of the good that humans have to offer, all of the feelings that humans try to express through song and word and art. Using a mix of bright pinks and cool teals, denims and knits, as well as plenty of glitter and shine, Sparklestar is Devinne's homage to the romance of sci-fi and a personal tale of love told through ready-to-wear garments. Take away from this space adventure a happy feeling; know that in this universe you are loved.

Morgan Wuch

Mini Collection *Street Chic*
Senior Collection *Bohemian Flair*

I grew up in St. Louis, Missouri, and from a young age I always loved clothing and fashion. It wasn't until my freshman year of high school, when I took my first clothing class, that I realized I wanted to make a career out of it. My designs are for women who are flirty and confident and are not afraid to push the envelope when it comes to fashion. We all have those days when we put on a great outfit and instantly feel like we can accomplish anything. My goal is for women to feel like that while they are wearing my designs.



Graduates

Amra Alihodzic



Couture Gown *Zuhair Murad*
Graduate Collection *Hommage*

Amra Alihodzic immigrated to the United States at the tender age of nine. "Submerged in a foreign land, not speaking the language nor relating to the culture... Art was an escape into a limitless fantasy where anything was possible." She always had a strong desire to make her mark creatively. She graduated with a BA in fashion design in fall 2011. Her inspirations are derived from all walks of life: art, nature, world travel, and fantasy. Amra completed an internship with the major retailer, Colin's, in Istanbul, Turkey, during summer 2012. After assisting the creative design department, she is certain that a career as a creative designer is where she belongs. Amra is expected to graduate with her Master of Arts in fashion design in fall 2013.

Altjin Batkhuu

Couture Gown *Zuhair Murad*
Graduate Collection *Hole*

Altjin was born in Ulaanbaatar, Mongolia, in 1989. Growing up she always had a strong interest in art and fashion design. In May 2012 she received her BFA in fashion design from Lindenwood University. Currently Altjin is pursuing a master's degree in fashion design. Her goal is to work for a well-known design house and ultimately launch her own line. Her latest collection, "Hole," represents sportswear with advanced pattern making techniques. Altjin wanted to design beautiful sportswear that had unusual elements with an expression of feminism. She distinguishes her designs for women who aim for elegance, yet like to make a statement by their appearance. Altjin's collection pursues the look of sophistication with a dark streetwise edge.



Special Thanks

Photography

Peter Wochniak, ProPhoto

Videographer

Gustav Gropp, LUTV

Lindenwood University Theatre Tech Department

Joe Stoltman - Production Manager

Tim Poertner - Lighting Director

Dustin Massie - Assistant Technical Director

Jim Koehnle - Technical Director

Drew Matney - House Audio Engineer

Sarah Thompson - Assistant House Audio Engineer

Hair and Makeup

Tspa, Salon Professional Academy, St Charles

Paul Mitchell The School, St Louis

Program and Program Cover

Angelia Duncan



Lindenwood University Fashion Show Committee

Lindenwood University Fashion Club

Fashion Show Production Class 2013

Fashion Design Faculty

Katrina Bennett, *MFA, Assistant Professor of Fashion Design*

Cynthia Cummins, *MSEd, Adjunct Faculty/Fashion Show Consultant*

Florence Dewan, *MFA, Associate Professor of Fashion Design*

Chajuana V. Trawick, *PhD, Assistant Professor of Fashion Design*

For more information about our Fashion Design program, please contact the
Admissions Office
(636) 949-4949



D's Place

SOULARD

www.dsplacesoulard.com

900 Barton

314-773-1019

Text dsplace to 96362 for our mobile app

D's Place offers great food including 1/2 pound certified angus beef burgers, homemade pizzas, and specialty chicken wing sauces.



Dan Drissell
Agent

17269 Wildhorse Creek Rd, Suite 130
Chesterfield, MO 63005-1360
Bus 636-532-2272
Fax 636-532-9929
Cell 314-283-8895
dan@dandrissell.com



The greatest compliment you can give is a referral.

BRONX diba
SHOES



Find us on:



WWW.DEMANDSHOES.COM



Your Source for
European Footwear
and Accessories!

- Footwear
- Accessories
- Clearance Specials
- Event/Holiday Sales
- Exclusive Styles
- Shoe Parties

3630 Corporate Trail Dr.
Earth City, MO 63045
(314)373-1280
M-F 8am-6pm Sat 11am-4pm

Decks & Patios • Windows
Remodeling • Retaining Walls
Drywall • Siding • Doors
Room Additions • Flatwork

Steve Rosso
ArchwayDesignLLC@Gmail.com
314.452.5791

Licensed & Fully Insured

VINTAGE & ESTATE JEWELRY

Finds for You

KAREN FOSTER

9830 Manchester Road
St. Louis, MO 63119

(314) 963-3313
Store Hours: Mon.-Sat. 10-6

vintageandestatejewelryfinds4u@yahoo.com



MEYER'S STEEL DETAILING
& CHECKING, INC.

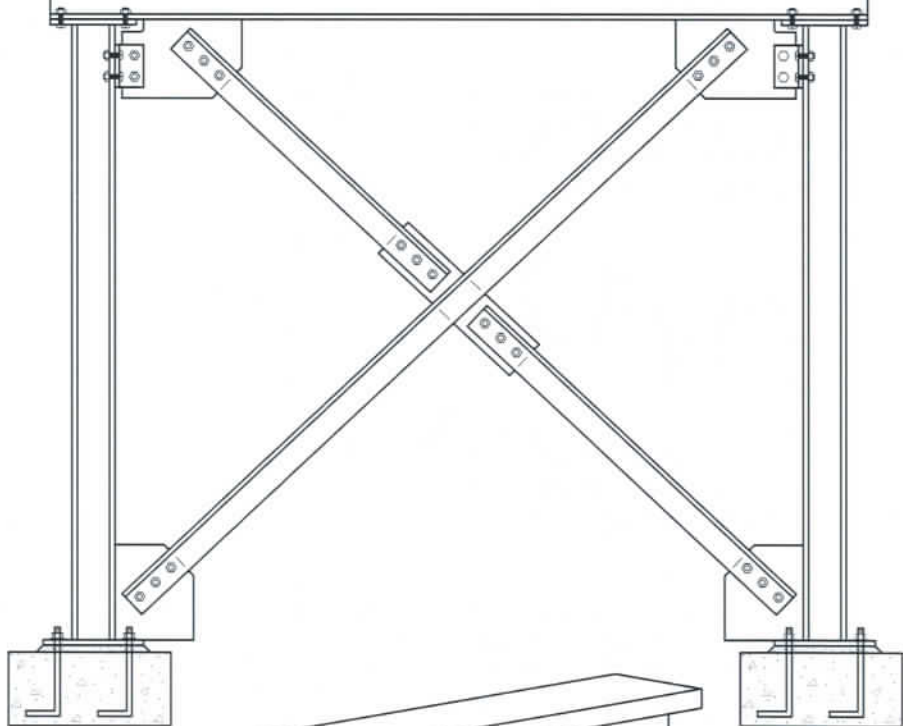

JOHN MEYER
12565 STATE RTE. 0
STE. GENEVIEVE MO. 63670
(573) 483-9898

Elektric Beach Tan

Home of the \$1.00 Tan!
We will beat any competitors pricing
including TanCo & Beauty World!
NEW BEACH CLUB MEMBERSHIP!!



Elektric Beach Tan
1030 Venture Drive
Saint Peters, MO 63376

636-922-1899
www.elektricbeachtan.com
www.facebook.com/elektricbeachtan

PAUL MITCHELL®

the school

S T . L O U I S

THE
SALON
PROFESSIONAL
ACADEMY

Bommarito of Hazelwood

WHERE PRICE SELLS CARS!



(314) 731-2228



HONDA

(314) 731-9777



(314) 731-7777



(314) 731-1222

AT THE BIG CORNER OF I-270 & N. LINDBERGH

*Proud To Support
Lindenwood University
Fashion Design Students
16th Annual Fashion Show*





LASER & DERMATOLOGIC SURGERY CENTER, INC.

314-878-3839 phone

www.lasersurgeryUSA.com

314-878-6575 fax



George J. Hruza, MD

Medical Director

Dr. Hruza, listed among the Best Doctors by St. Louis magazine for over a decade, is Clinical Professor of Dermatology at St. Louis University and Director of the Laser & Dermatologic Surgery Center. He received his medical degree from New York University at the top of his class and is a member of Phi Beta Kappa and Alpha Omega Alpha Honorary Societies. He completed his dermatology residency at New York University Medical Center followed by a laser surgery fellowship at Harvard Medical School. Dr. Hruza is a Diplomate of the American Board of Dermatology and Laser Surgery. He is President of the American Society for Laser Medicine and Surgery and Vice President of the American Society for Dermatologic Surgery. He has authored more than 140 scientific papers and 2 textbooks on laser surgery as well as lecturing on and teaching laser surgery on 4 continents.

Ramona Behshad, MD



Dr. Ramona Behshad is a board certified dermatologist and fellowship trained skin surgeon. During her medical training, Dr. Behshad refined her skills as a skin cancer specialist and received extensive hands-on training in laser and other cosmetic dermatologic procedures. Prior to her fellowship in St. Louis, she completed 10 years of post-graduate training in Cleveland, Ohio. She received her undergraduate and medical degrees with highest honors from Case Western Reserve University and is a member of the Alpha Omega Alpha and Phi Beta Kappa honor societies. She continued her post-graduate training at University Hospitals/Case Medical Center, where she completed her dermatology residency.

Services Offered

Botox™
Dysport®
Xeomin®
Nail Surgery
Chemical Peels
Lip Enhancement
Wrinkle Reduction
Laser Hair Removal
Reduce Spider Veins

Scar Revision
Skin Resurfacing
Skin Rejuvenation
Microdermabrasion
Improve Skin Texture
Skin Care Consultations
Tighten Sun-Damaged Skin
Acne/Surgical Scar Reduction
Fade Tattoos/Age Spots/Birthmarks

Mention this ad and receive a FREE skin analysis

1001 Chesterfield Parkway East • Suite 101 • Chesterfield • Missouri • 63017